

HYBRID

SISTEMA CORREDERA CON ROTURA DE
PUENTE TÉRMICO

rotura de puente térmico mediante varillas de
poliamida PA 6.6 GF 25 de 24 y 30 mm

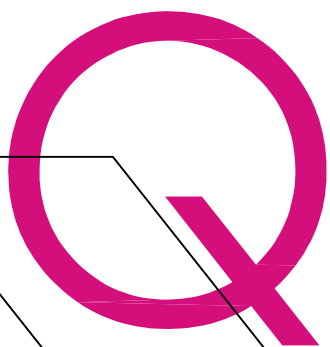

systems

aluminio

INDICE

1_ Características técnicas de la serie

2_ Accesorios y juntas

3_ Relación de perfiles

4_ Perfiles y Acristalamiento

5_ Nudos

6_ Lista de corte

FICHA TÉCNICA HYBRID

Secciones	Marcos de 67, 83 y 95 mm Hoja perimetral de 37mm y cruce de 30 mm
Longitud de poliamida	24 y 30 mm. Poliamida 6.6 con 25% de fibra de vidrio
Acristalamiento	Hasta 30 mm
Dimensiones máximas	Ancho (L) = 1700 mm y alto (H) = 2500 mm (consultar dimensiones máximas según tipología)
Peso máximo por hoja	170 kg. (consultar dimensiones máximas según tipología)

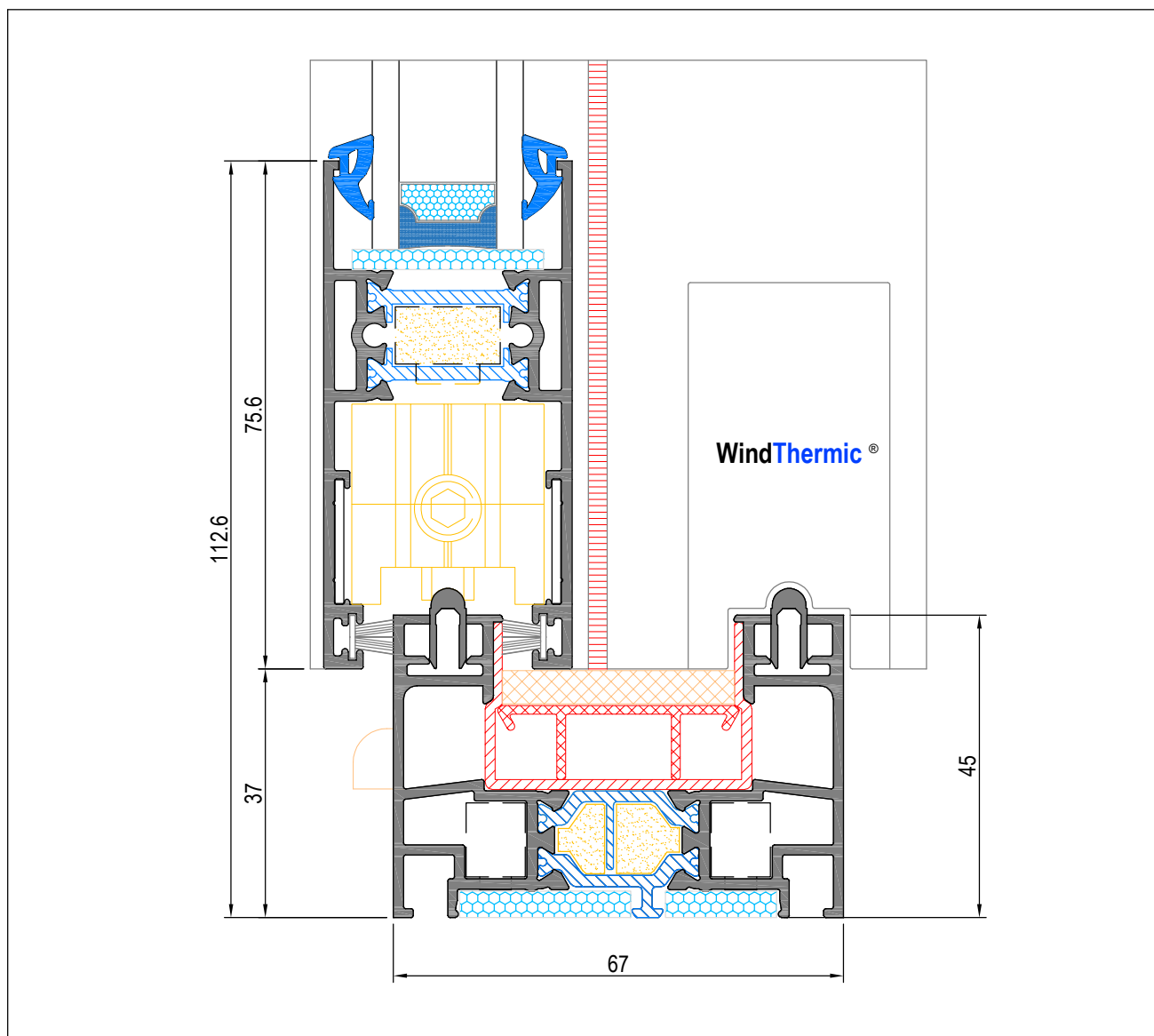

DATOS TÉCNICOS

CLASIFICACIONES DE ENSAYOS

Ensayos de aire, agua y viento

VENTANA DE DOS HOJAS

Permeabilidad al aire
UNE-EN 1026:2017 UNE-EN 12207:2017

CLASE 1	CLASE 2	CLASE 3	CLASE 4
---------	---------	----------------	---------

Estanqueidad al agua
UNE-EN 1027:2017 UNE-EN 12208:2000

1A	2A	3A	4A	5A	6A	7A	8A	9A	E1800
----	----	----	----	----	-----------	----	----	----	-------

Resistencia al viento
UNE-EN 12211:2017 UNE-EN 12210:2017

CLASE C1	CLASE C2	CLASE C3	CLASE C4	CLASE C5
----------	----------	----------	----------	-----------------

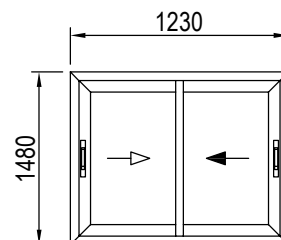

BALCONERA DE DOS HOJAS

Permeabilidad al aire
UNE-EN 1026:2017 UNE-EN 12207:2017

CLASE 1	CLASE 2	CLASE 3	CLASE 4
---------	---------	---------	----------------

Estanqueidad al agua
UNE-EN 1027:2017 UNE-EN 12208:2000

1A	2A	3A	4A	5A	6A	7A	8A	9A	E1800
----	----	----	----	----	-----------	----	----	----	-------

Resistencia al viento
UNE-EN 12211:2017 UNE-EN 12210:2017

CLASE C1	CLASE C2	CLASE C3	CLASE C4	CLASE C5
----------	----------	----------	-----------------	----------

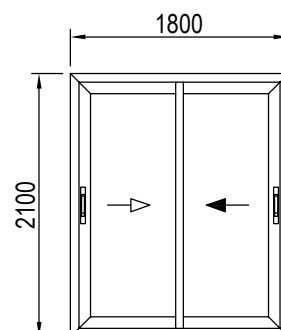

Ensayos térmicos

Transmitancia térmica
UNE-EN 10077-1:2006

Ug	Denominación	Uw
1,3 W/m²K	Ventana de dos hojas corredera 1230x1480	1,8 W/m²K
1,4 W/m²K	Ventana de dos hojas corredera 1230x1480	1,9 W/m²K
1,0 W/m²K	Ventana de dos hojas corredera 1230x1480	1,5 W/m²K
0,6 W/m²K	Ventana de dos hojas corredera 1230x1480	1,2 W/m²K

Ensayos acústicos

Aislamiento acústico
UNE-EN 14351-1:2006+A2:2017

Acristalamiento	Denominación	Uw
36(-3;-7) dB	Ventana de dos hojas corredera 1230x1480	37 (-1;-5) dB

COEFICIENTE DE TRANSMITANCIA TÉRMICA

SOLUCIÓN EF+

$U_f = 3.1 \text{ W/m}^2\text{K}$

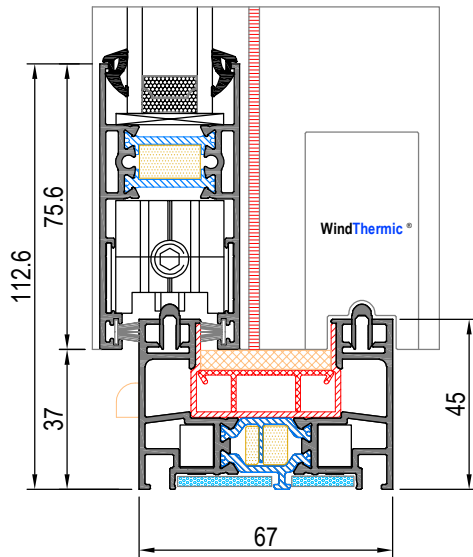

COEFICIENTE DE TRANSMITANCIA TÉRMICA

SOLUCIÓN BASICA

$U_f = 3.4 \text{ W/m}^2\text{K}$

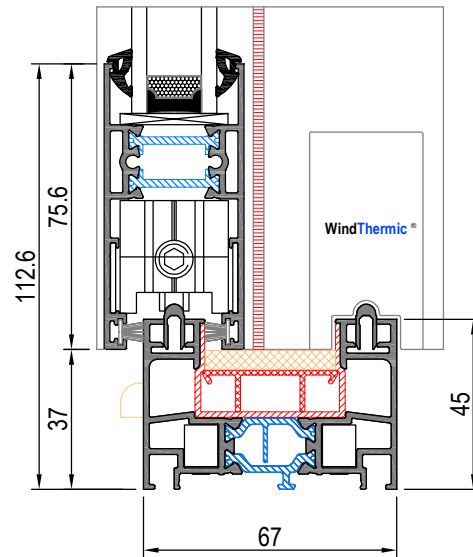

Cálculo de transmitancia térmica (U_w) para ventana de dos hojas con dimensiones 1500x2200

SOLUCIÓN EF+	INTERCALARIO VIDRIO	ψ_g [W/mK]	VIDRIO DOBLE				
			U_g [W/m ² K]				
			1.9	1.6	1.3	1.1	0.9
ALUMINIO	0.110	2.6	2.4	2.2	2.0	1.9	
SPACER M TECHNOFORM	0.049	2.4	2.2	2.0	1.8	1.7	
SPACER PRECISION TECHNOFORM	0.036	2.4	2.1	1.9	1.8	1.6	

SOLUCIÓN BÁSICA	INTERCALARIO VIDRIO	ψ_g [W/mK]	VIDRIO DOBLE				
			U_g [W/m ² K]				
			1.9	1.6	1.3	1.1	0.9
ALUMINIO	0.110	2.7	2.4	2.2	2.1	1.9	
SPACER M TECHNOFORM	0.049	2.5	2.2	2.0	1.9	1.7	
SPACER PRECISION TECHNOFORM	0.036	2.5	2.2	2.0	1.8	1.7	

COEFICIENTE DE TRANSMITANCIA TÉRMICA

SOLUCIÓN EF+

$U_f = 3.1 \text{ W/m}^2\text{K}$

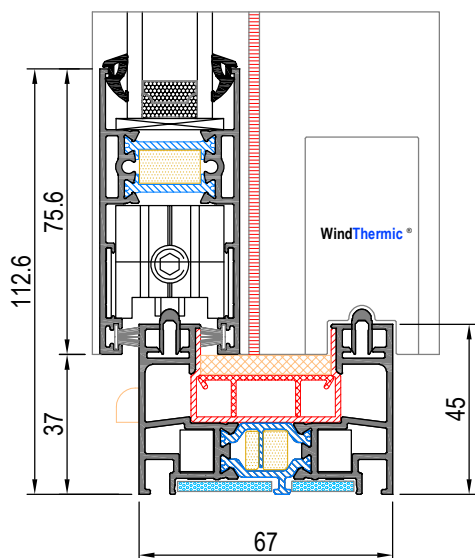

COEFICIENTE DE TRANSMITANCIA TÉRMICA

SOLUCIÓN BÁSICA

$U_f = 3.4 \text{ W/m}^2\text{K}$

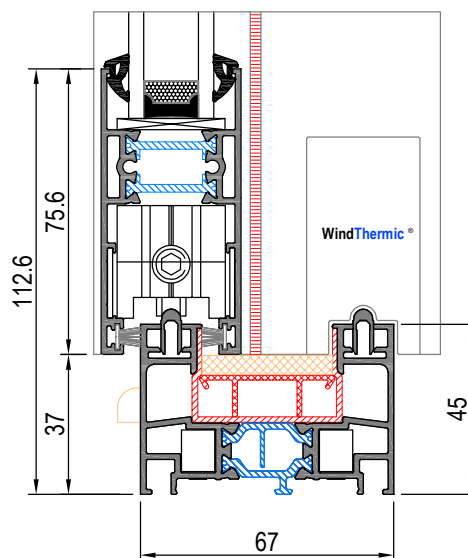

Cálculo de transmitancia térmica (U_w) para ventana de dos hojas con dimensiones 4000x2500

SOLUCIÓN EF+	INTERCALARIO VIDRIO	ψ_g [W/mK]	VIDRIO DOBLE				
			U_g [W/m2K]				
			1.9	1.6	1.3	1.1	0.9
	ALUMINIO	0.110	2.3	2.0	1.8	1.6	1.4
	SPACER M TECHNOFORM	0.049	2.2	1.9	1.7	1.5	1.3
	SPACER PRECISION TECHNOFORM	0.036	2.2	1.9	1.6	1.5	1.3

SOLUCIÓN BÁSICA	INTERCALARIO VIDRIO	ψ_g [W/mK]	VIDRIO DOBLE				
			U_g [W/m2K]				
			1.9	1.6	1.3	1.1	0.9
	ALUMINIO	0.110	2.3	2.1	1.8	1.6	1.5
	SPACER M TECHNOFORM	0.049	2.2	2.0	1.7	1.5	1.4
	SPACER PRECISION TECHNOFORM	0.036	2.2	1.9	1.7	1.5	1.3

SELECCIÓN DEL PERFIL CENTRAL SEGÚN DIMENSIONES DE HOJA

Clasificación deformación según UNE-EN 12210:2000
hoja perimetral 82300 ($I_x = 5,10 \text{ cm}^4$)

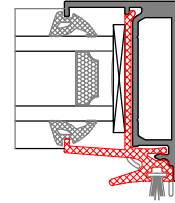

DIMENSIONES MÁXIMAS

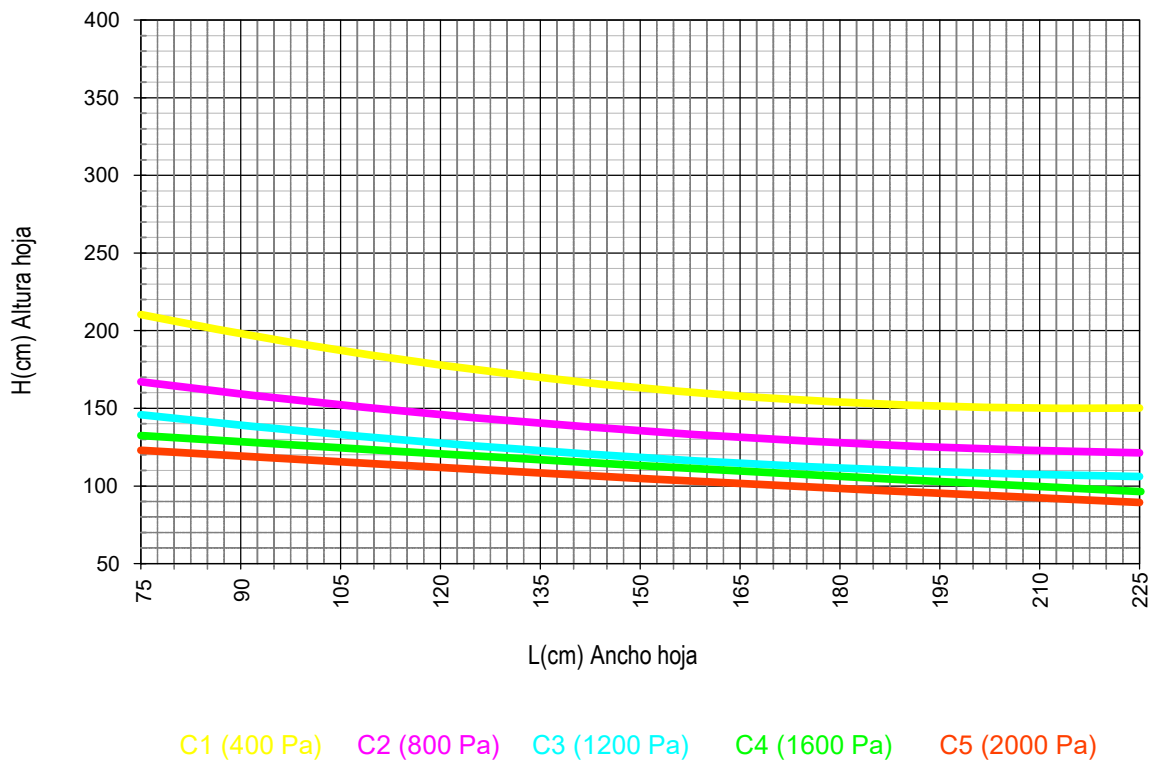

C1 (400 Pa) C2 (800 Pa) C3 (1200 Pa) C4 (1600 Pa) C5 (2000 Pa)

Clasificación de la ventana según norma UNE-EN 12210	
Clase	Carga de Viento
1	400 Pa - 93 km/h
2	800 Pa - 131 km/h
3	1200 Pa - 161 Km/h
4	1600 Pa - 186 km/h
5	2000 Pa - 208 km/h
Exxxx	xxxx

Clasificación de la flecha relativa según norma UNE-EN 12210	
Clase	Flecha Frontal
A	< 1/150
B	< 1/200
C	< 1/300

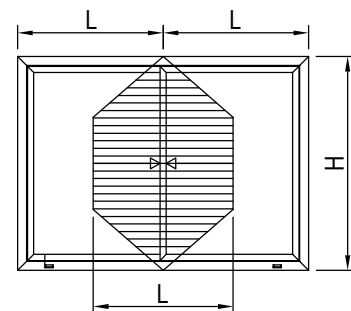

Nota: estos valores son orientativos, ya que el número de puntos de cierre puede variar el resultado final.

SELECCIÓN DEL PERFIL CENTRAL SEGÚN DIMENSIONES DE HOJA

Clasificación deformación según UNE-EN 12210:2000
 hoja perimetral 82300 ($I_x = 10,47 \text{ cm}^4$)
 Refuerzo de pletina de acero 30x8

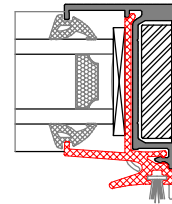

DIMENSIONES MÁXIMAS

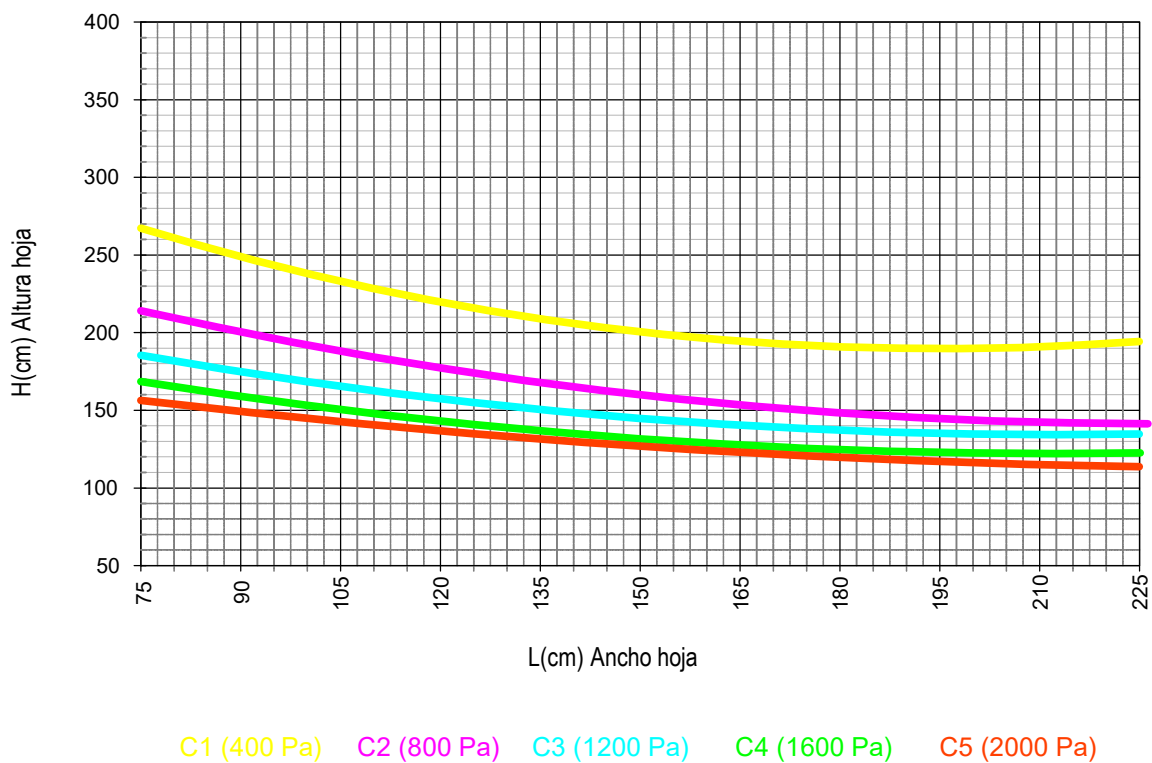

Clasificación de la ventana según norma UNE-EN 12210	
Clase	Carga de Viento
1	400 Pa - 93 km/h
2	800 Pa - 131 km/h
3	1200 Pa - 161 Km/h
4	1600 Pa - 186 km/h
5	2000 Pa - 208 km/h
Exxx	xxxx

Clasificación de la flecha relativa según norma UNE-EN 12210	
Clase	Flecha Frontal
A	< 1/150
B	< 1/200
C	< 1/300

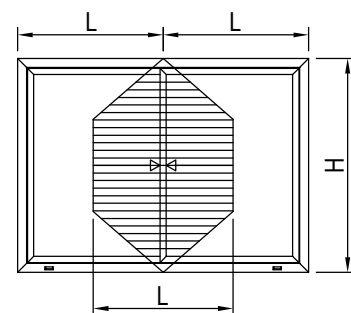

Nota: estos valores son orientativos, ya que el número de puntos de cierre puede variar el resultado final.

SELECCIÓN DEL PERFIL CENTRAL SEGÚN DIMENSIONES DE HOJA

Clasificación deformación según UNE-EN 12210:2000
hoja perimetral 82300 ($I_x = 30,36 \text{ cm}^4$)

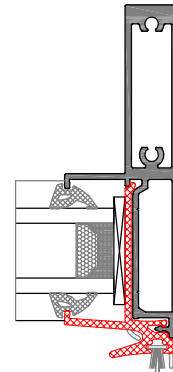

DIMENSIONES MÁXIMAS

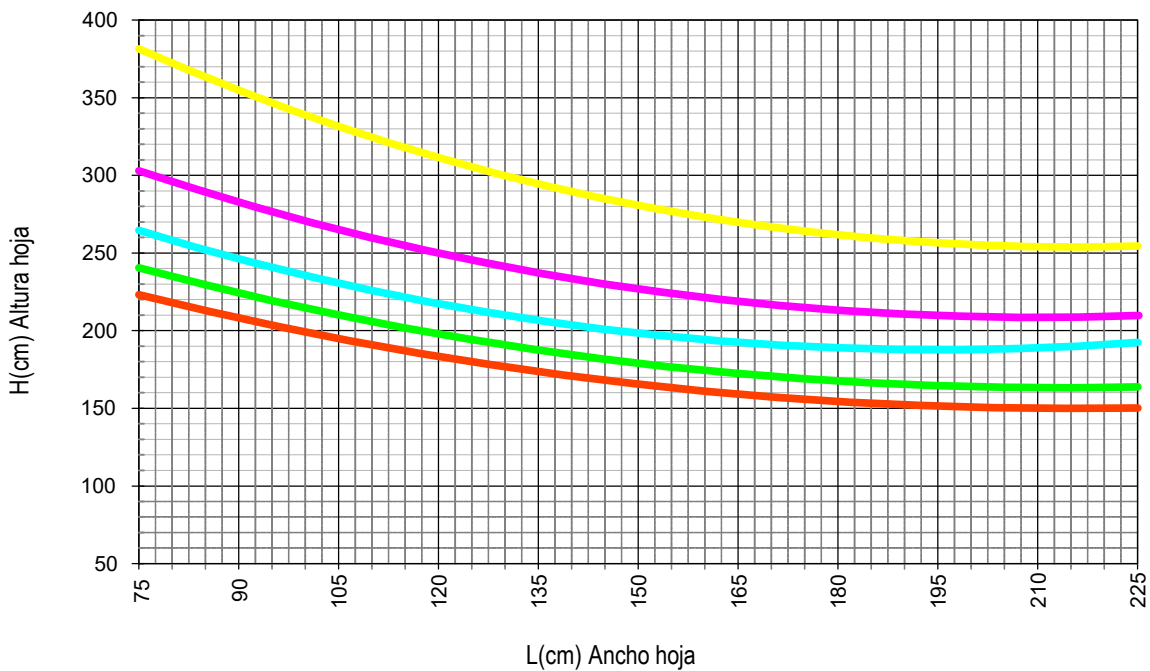

C1 (400 Pa) C2 (800 Pa) C3 (1200 Pa) C4 (1600 Pa) C5 (2000 Pa)

Clasificación de la ventana según norma UNE-EN 12210	
Clase	Carga de Viento
1	400 Pa - 93 km/h
2	800 Pa - 131 km/h
3	1200 Pa - 161 Km/h
4	1600 Pa - 186 km/h
5	2000 Pa - 208 km/h
Exxx	xxxx

Clasificación de la flecha relativa según norma UNE-EN 12210	
Clase	Flecha Frontal
A	< 1/150
B	< 1/200
C	< 1/300

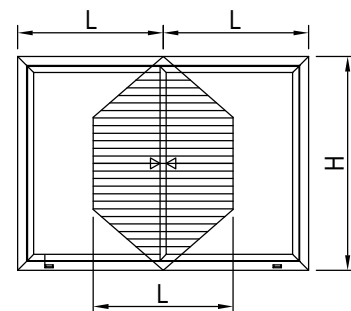

Nota: estos valores son orientativos, ya que el número de puntos de cierre puede variar el resultado final.

SELECCIÓN DEL PERFIL CENTRAL SEGÚN DIMENSIONES DE HOJA

Clasificación deformación según UNE-EN 12210:2000
 hoja perimetral 82303 ($I_x = 38,57 \text{ cm}^4$)
 Refuerzo de rectangular de acero 30x10

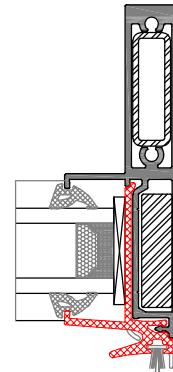

DIMENSIONES MÁXIMAS

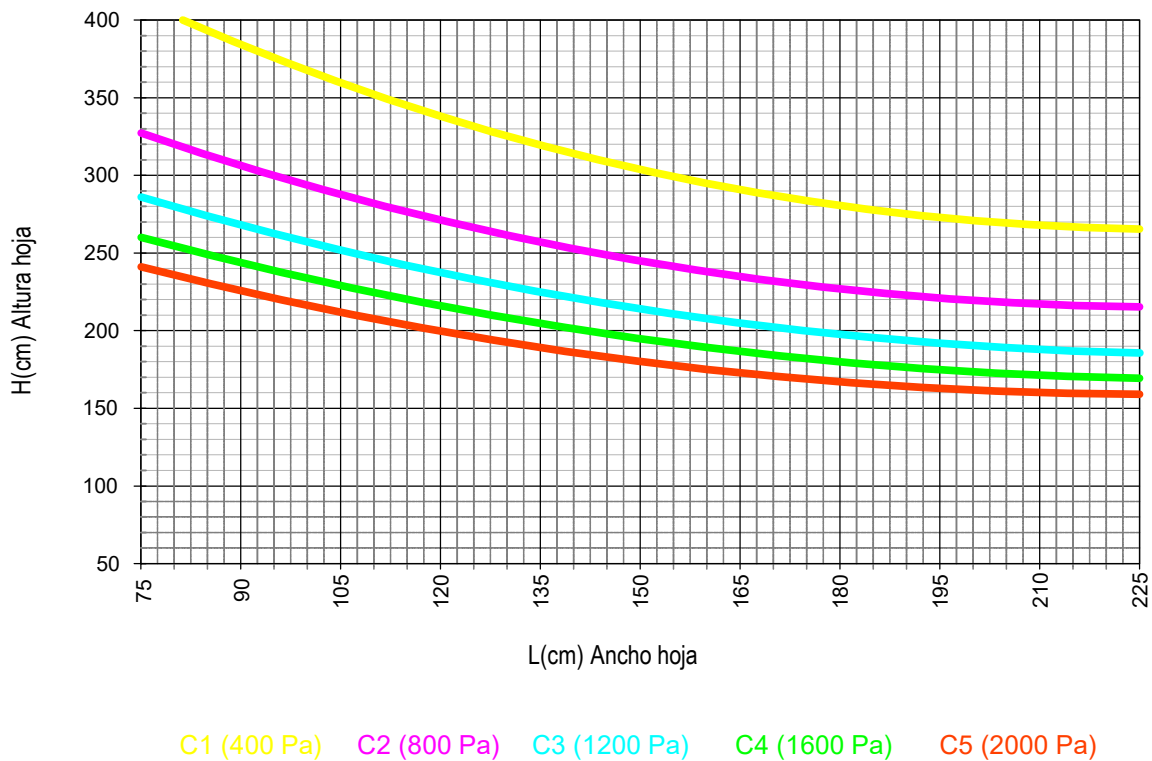

Clasificación de la ventana según norma UNE-EN 12210	
Clase	Carga de Viento
1	400 Pa - 93 km/h
2	800 Pa - 131 km/h
3	1200 Pa - 161 Km/h
4	1600 Pa - 186 km/h
5	2000 Pa - 208 km/h
Exxx	xxxx

Clasificación de la flecha relativa según norma UNE-EN 12210	
Clase	Flecha Frontal
A	< 1/150
B	< 1/200
C	< 1/300

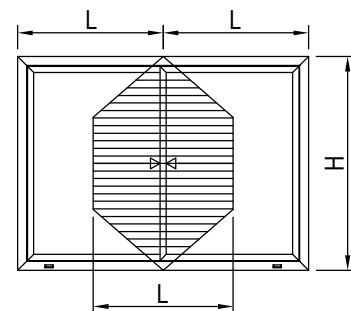







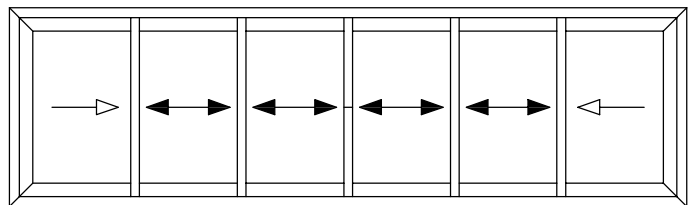
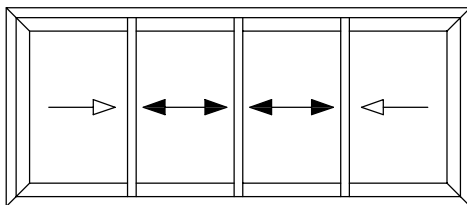
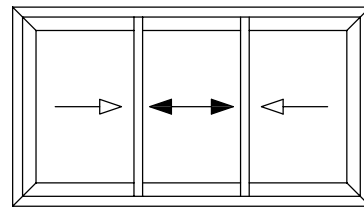
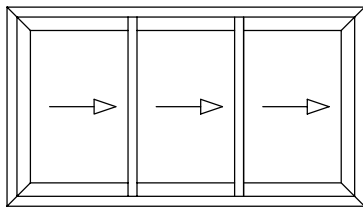
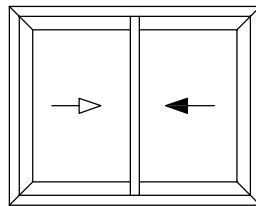

Nota: estos valores son orientativos, ya que el número de puntos de cierre puede variar el resultado final.

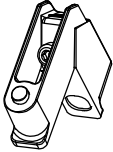
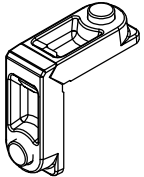
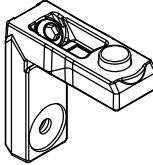
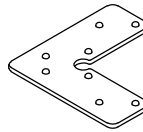
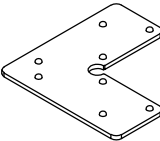
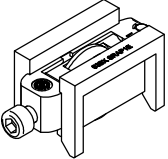
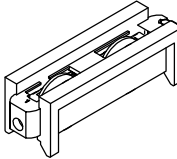
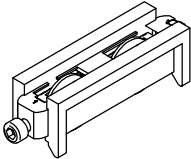
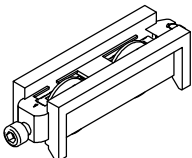
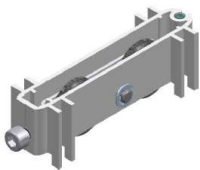
POSIBILIDADES DE APERTURA

CORREDERA
CORREDERA ELEVABLE

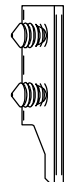
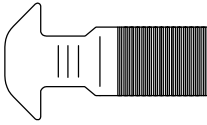

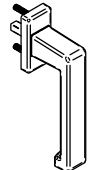
aluminio **Accesorios**

<p>0100911</p>  <p>Escuadra 9 x 11</p>	<p>0101911</p>  <p>Escuadra 19,5 x 11</p>	<p>0101508</p>  <p>Escuadra 15 x 8</p>	<p>0114212</p>  <p>Escuadra alineamiento inox. 14 x 1</p>
<p>0118412</p>  <p>Escuadra alineamiento inox. 18 x 1</p>	<p>0808001</p>  <p>Carro simple regulable 80 kg x hoja</p>	<p>0816002</p>  <p>Carro doble fijo 160 kg x hoja</p>	<p>0816203</p>  <p>Carro doble regulable 160 kg x hoja</p>
<p>0812004</p>  <p>Carro doble regulable inox 200 kg x hoja</p>	<p>0825005</p>  <p>Carro doble reg. (carril inox) 250 kg x hoja</p>	<p>0814506</p>  <p>Cierre embutido 145</p>	<p>0818507</p>  <p>Cierre embutido 185</p>
<p>0814508</p>  <p>Cierre embutido 145 con tornillo</p>	<p>0814509</p>  <p>Tirador para cierre embutido 145</p>	<p>0810010</p>  <p>Cerradero marco</p>	<p>0810011</p>  <p>Gancho cierre</p>
<p>0840029</p>  <p>Cierre recto con tirador recto para multipunto</p>	<p>0840030</p>  <p>Cierre curvo con tirador recto para multipunto</p>	<p>0840031</p>  <p>Manilla para multipunto</p>	<p>0840032</p>  <p>Manilla plana para multipunto</p>

0840019



Cierre 1 punto

0840020



Cierre 2 puntos
650 mm opción bombín

0840021



Cierre 2 puntos
650 mm

0840022



Cierre 3 puntos
1150 mm opción bombín

0840023



Cierre 4 puntos
1500 mm opción bombín

0840024

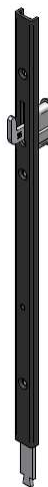

Alargador 1 punto
500 mm

0840025

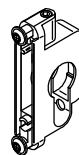

Adaptador bombín europeo

0840033



Calzo para multipunto
(1ud por punto de cierre)

0840027



Cierre curvo grande
para multipunto

0840028



Cierre curvo pequeño
para multipunto

0830012

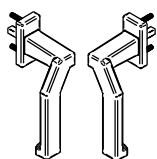

Manilla acodada D/I
para multipunto

0840026



Cierre para multipunto

0830013

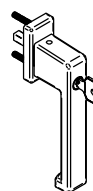

Manilla para multipunto
con llave

0830014

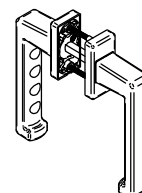

Manilla doble
para multipunto

0830017



Manilla Xeno para multipunto grande

0830018



Manilla Xeno para multipunto pequeña

0830015



Escudo metálico con tornillo

0830016



Escudo plástico adhesivo

1770019

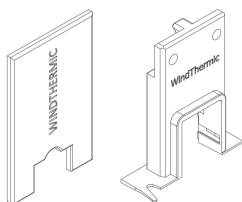

Conjunto tapas de cruce Dx y lx (una hoja)

1770020

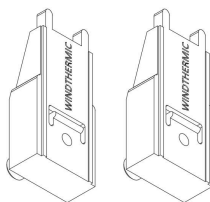

Conjunto Tope lateral hoja (una hoja)

1770021

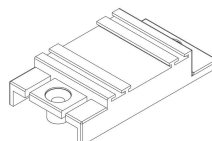

Cortavientos superior / inferior

0106580



Felpa con film hoja

0105075



Felpa de cruce con film

0106575



Felpa tres láminas hoja

0105070



Felpa tres láminas cruce

TRT0005

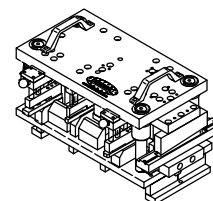

Troquel Hybrid

0509025

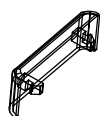

Tapa salida de guas

82301

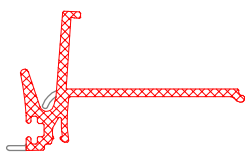

Perfil PVC de cruce

82302

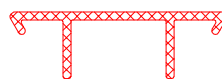

Perfil PVC para marco

14100



Perfil PVC U de marco



Refuerzo 30x8

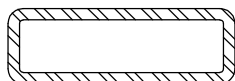

Refuerzo 30x10

0000070

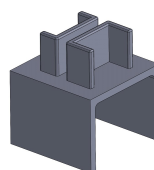





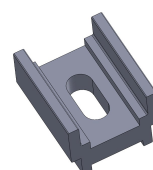



Tapón de 4 hojas

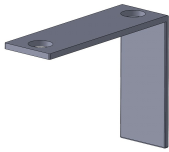

0000080





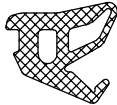
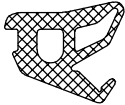



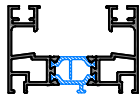
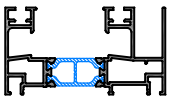
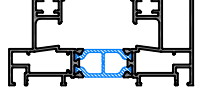
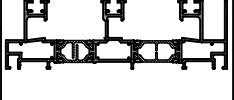
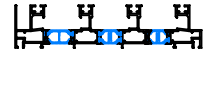
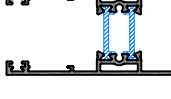
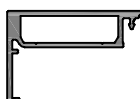
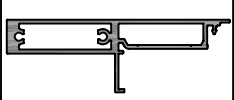

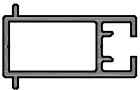
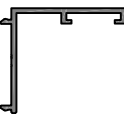

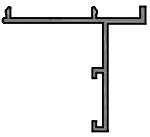

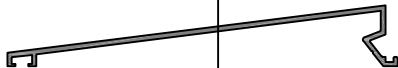
Centrador 4 hojas / mpto



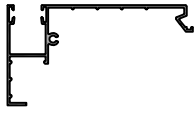
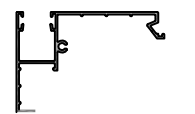
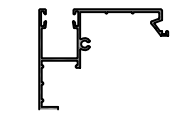
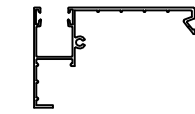
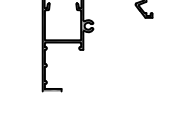

aluminio

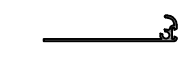
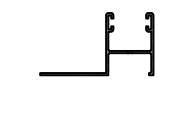
<p>0000040</p>  <p>Tapa refuerzo Hybrid</p>			
<p>03612746</p>  <p>Junta cierre canal marco</p>	<p>03612745</p>  <p>Junta perimetral</p>	<p>0304010</p>  <p>Junta interior hoja Junta exterior acristalar</p>	<p>0304896</p>  <p>Junta acrist. inte. 3 mm.</p>
<p>0304897</p>  <p>Junta acrist. inte. 4 mm.</p>	<p>0304898</p>  <p>Junta acrist. inte. 5 mm.</p>	<p>0304899</p>  <p>Junta acrist. inte. 6/7 mm.</p>	<p>0304890</p>  <p>Junta acrist. inte. 8/9 mm.</p>
<p>0304891</p>  <p>Junta acrist. inte. 10 mm.</p>			

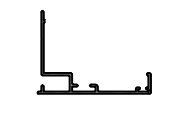
Referencia	Diseño	Descripción	Peso (Gr/mt)	Perímetro Total(mm)
82005		carril rodadura aluminio	80	48.7
A-07381				
82006		carril rodadura inox		
82100		marco 67	1342	708.6
RPT-00785				
82101		marco 83.1	1555	826
RPT-00783				
82102		marco 95.5	1686	894
RPT-00784				
82132		marco tricarril 146	2436	1312
RPT-00825				
82133		marco cuatro carriles 197	3186	1752
82200		Hoja perimetral	1144	572
RPT-00786				
82300		Hoja central	602	254.7
A-14310				
82303		Perfil reforzado de cruce	1192	477
A-15542				

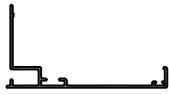
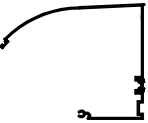
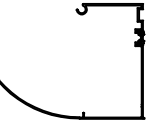
Referencia	Diseño	Descripción	Peso (Gr/mt)	Perímetro Total(mm)
82304		Perfil unión 4 hojas	461	228
A-16671				
40030		solape de 30 mm.	240	144.4
CI-033-40030				
40033		solape de 45 mm.	294	174.6
CI-033-40033				
40037		solape con bandeja de condensación	293	170.5
CI-033-40037				
00123		vierteaguas 58.2 mm.	305	178.99
CI-026-00123				
00122		vierteaguas 68.2 mm.	337	198.42
CI-026-00122				
40082		vierteaguas 100 mm.	454	266.4
CI-033-40082				
00143		solape clipado de 30 mm.	178	107.5
CI-010-0143				
40034		solape clipado de 45 mm.	178	107.5
CI-010-0143				
20123		postizo interior para guia de persiana	356	205.09
CI-010-20123				

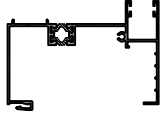
Referencia	Diseño	Descripción	Peso (Gr/mt)	Perímetro Total(mm)
30006		guia de persiana de 98.2 mm.	864	483.52
CI-010-30006				
30007		guia de persiana de 75 mm.	781	440.89
CI-010-30007				
30010		guia de persiana de 65 mm.	738	419.12
CI-010-30010				
30011		guia de persiana de 85 mm.	824	462.67
CI-010-30011				
30012		guia de persiana de 55 mm.	692	395.58
CI-010-30012				
0058		cortavientos interior persiana	236	143
CI-026-0058				
1210		cortavientos exterior persiana	488	239
CI-164-1210				
20117		guia de persiana con pala de 60 mm.	459	284
CI-010-20117				
A-7181		tapajuntas reg. pers. de 40 mm.	363	224.6
10481		tapajuntas reg. pers. de 57 mm.	503	291.7

Referencia	Diseño	Descripción	Peso (Gr/mt)	Perímetro Total(mm)
10482		tapajuntas reg. pers. de 82 mm.	591	341.7
45067		semi esquinero regulable 120 mm (A)	1606	801.5
RPT-033-45067				
45065		semi esquinero regulable 120 mm (B)	1595	804.4
RPT-033-45065				
0901720		perfil de PVC	-	-
45071		guía de persiana con rotura 100 mm	1310	723.1
RPT-033-45071				
45072		guía de persiana con rotura 120 mm	1334	736.4
RPT-033-45072				
45074		guía de persiana con rotura 140 mm	1380	7632
RPT-033-45074				

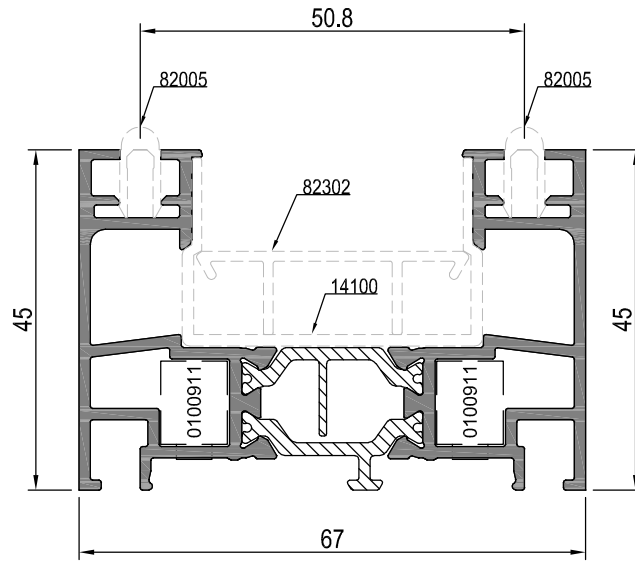

82100

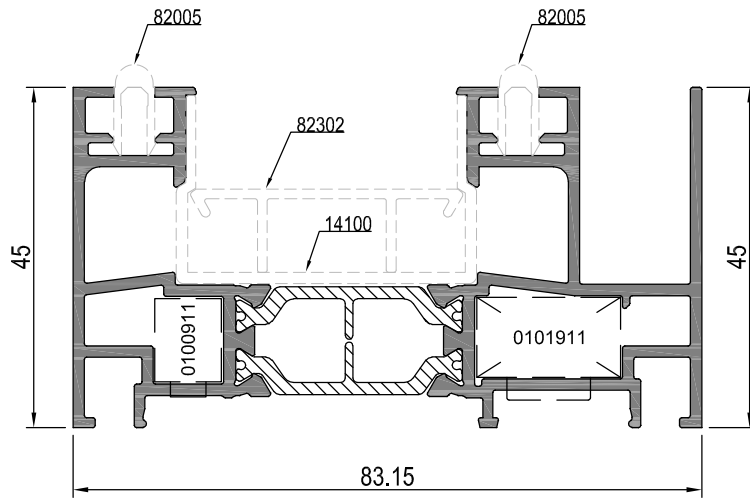

82101

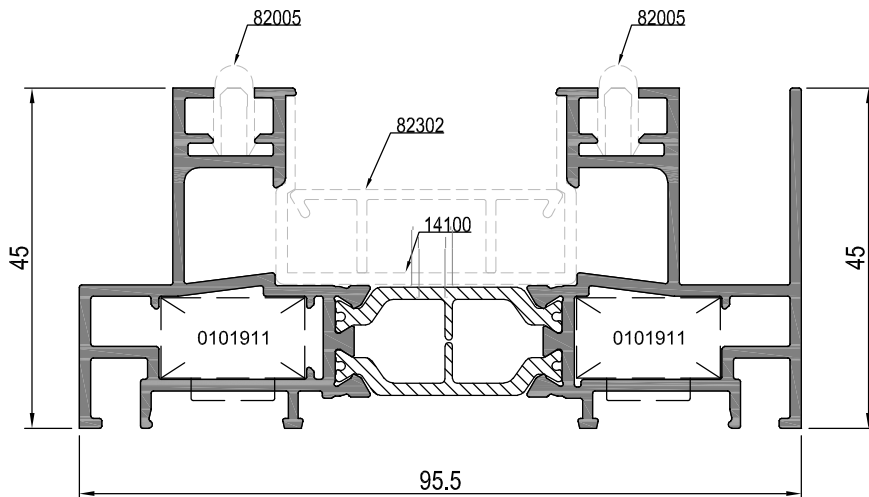

82102

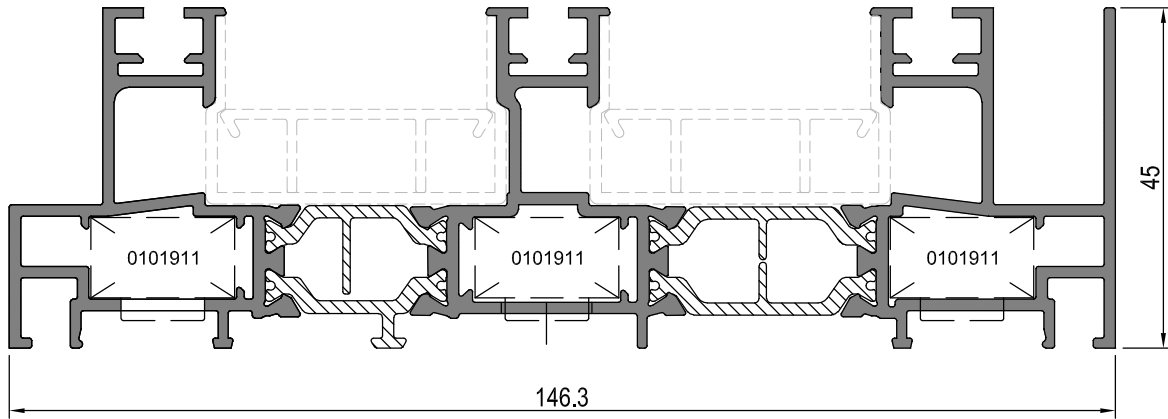

82132

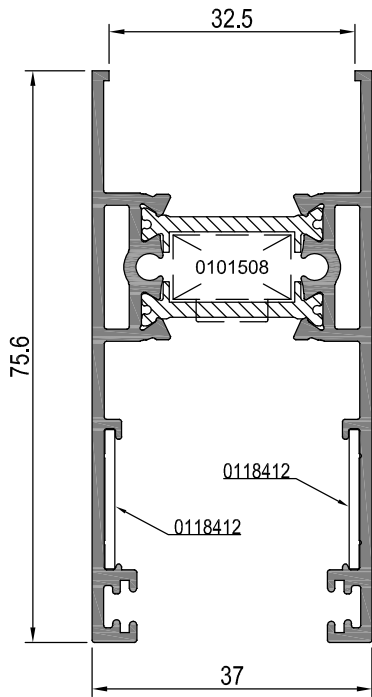

82200

14100

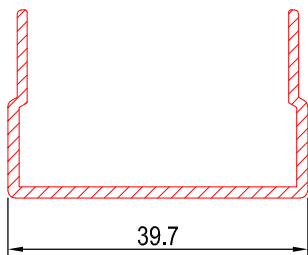

82302

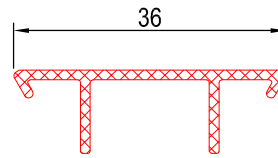

82301

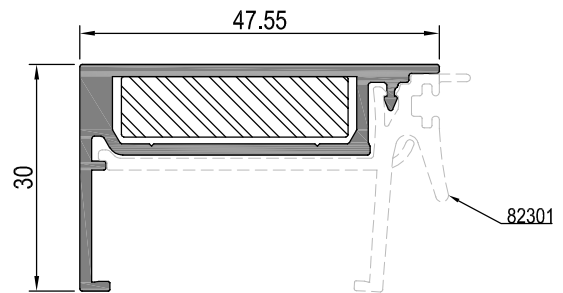
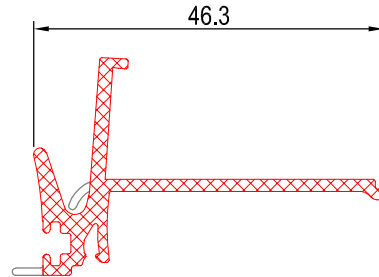

82300

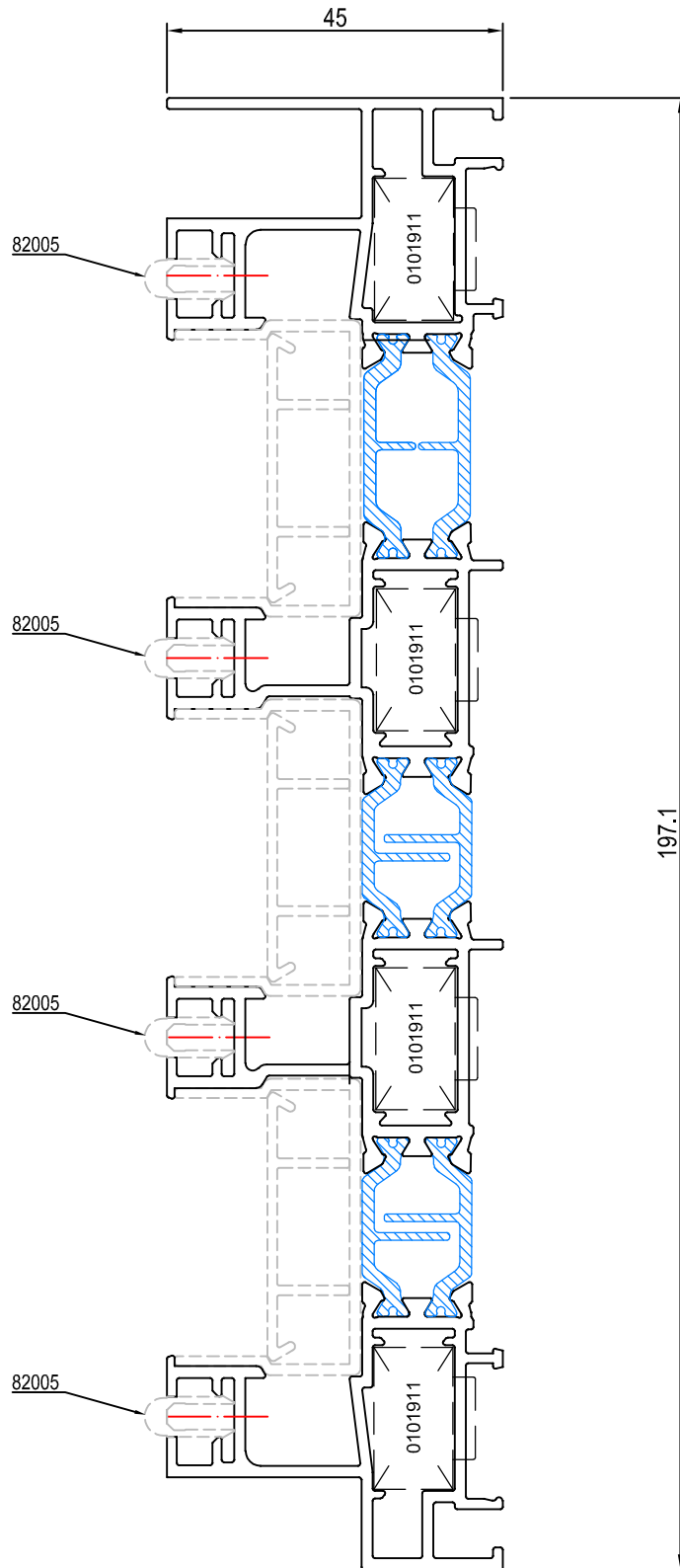

82133

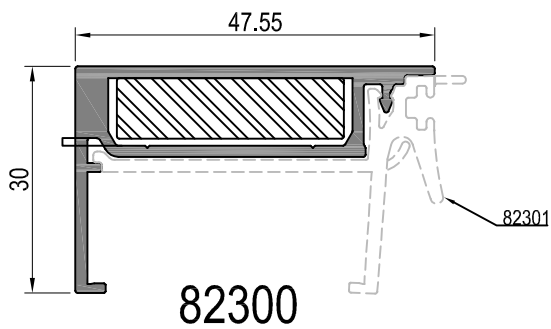

82301

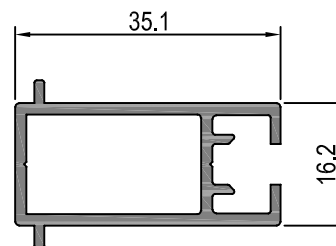
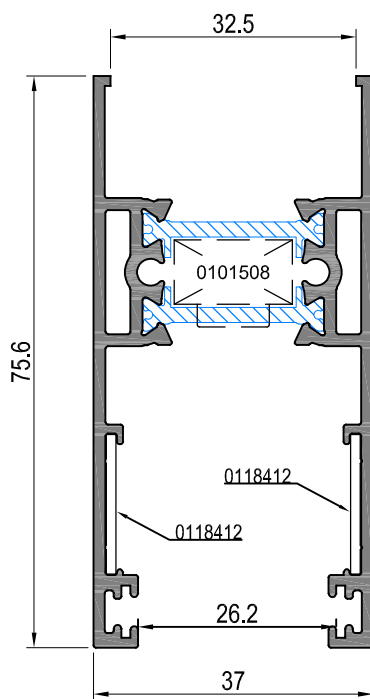
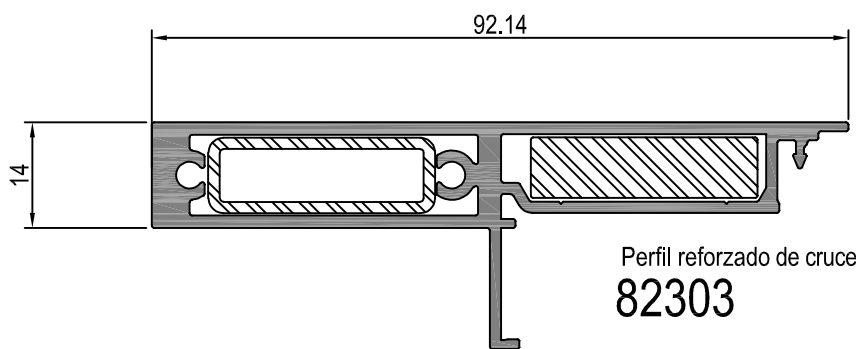
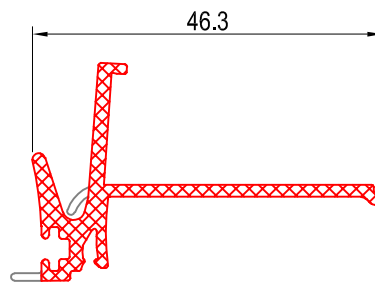

Perfil unión 4 hojas
82304

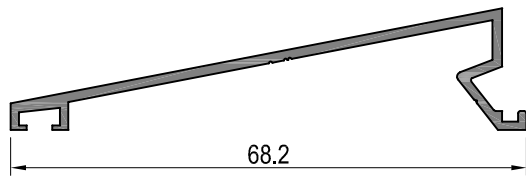
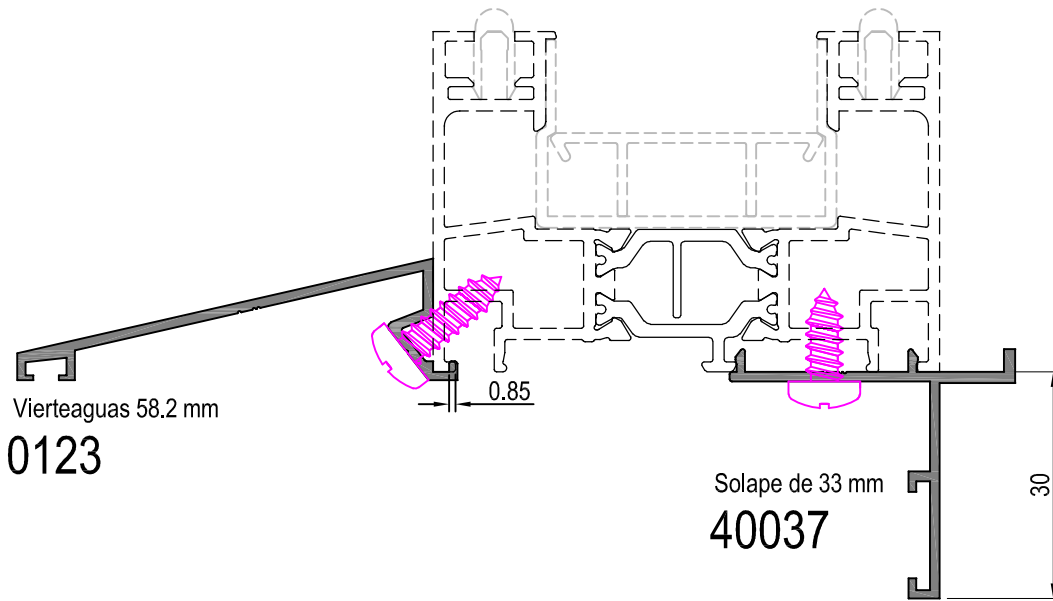

Vierteaguas 68.2 mm
0122

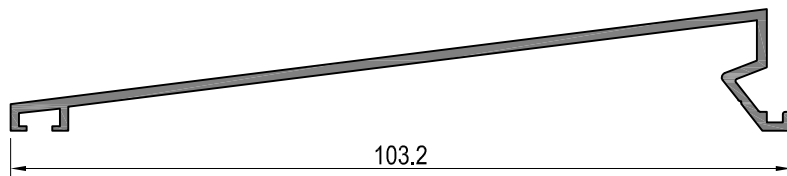
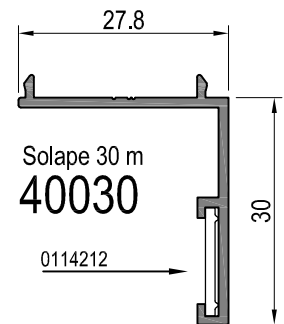

Vierteaguas 100 mm
40082

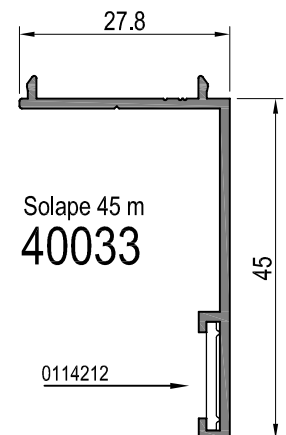

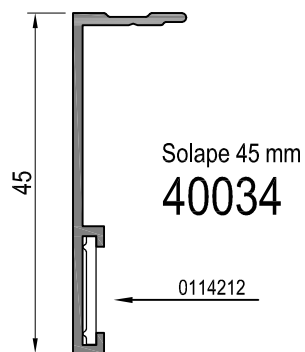
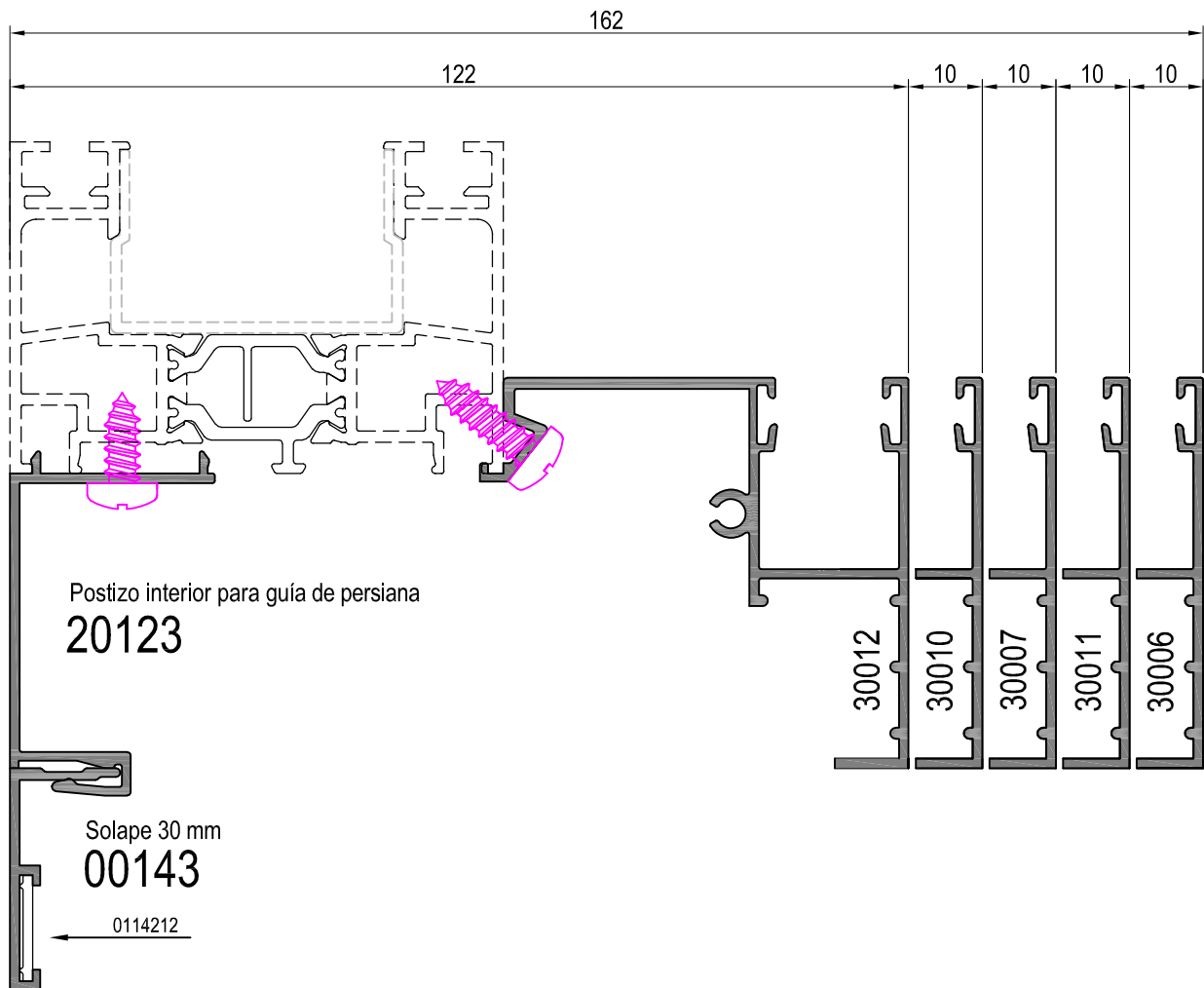

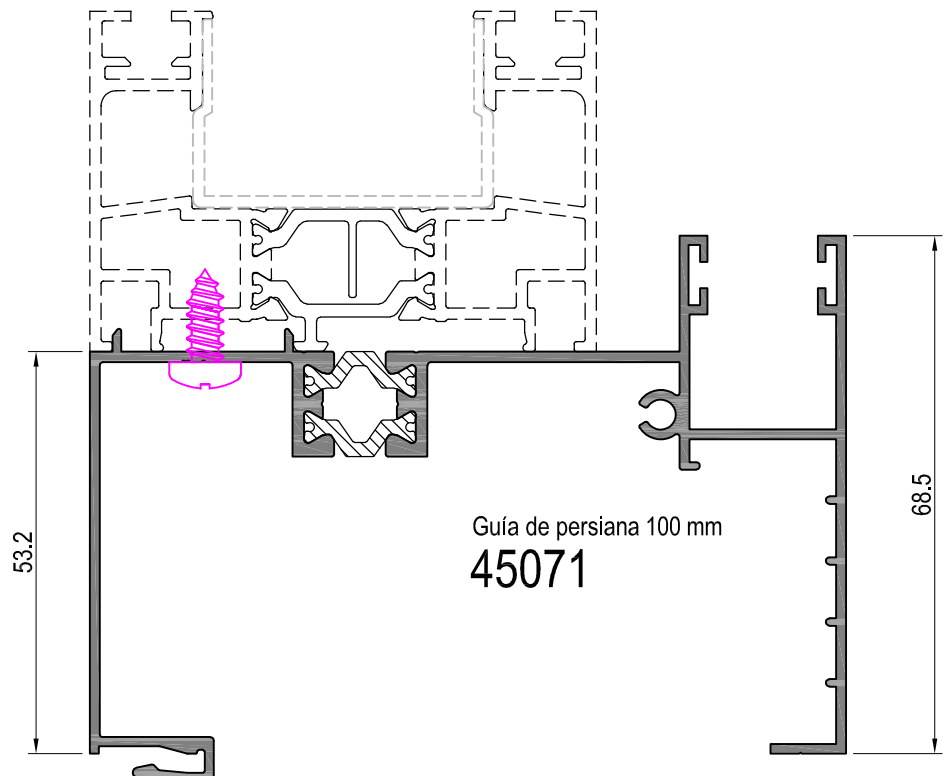
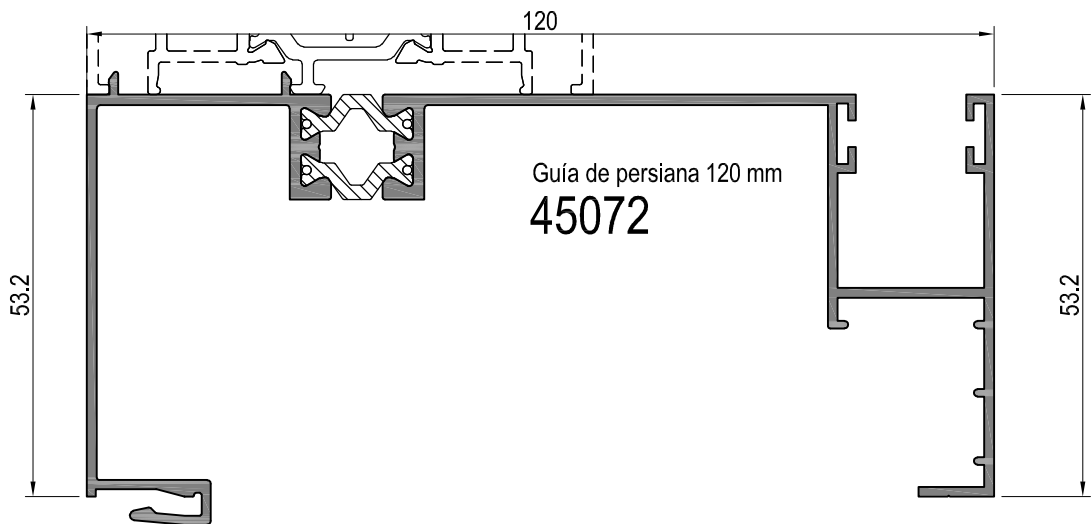
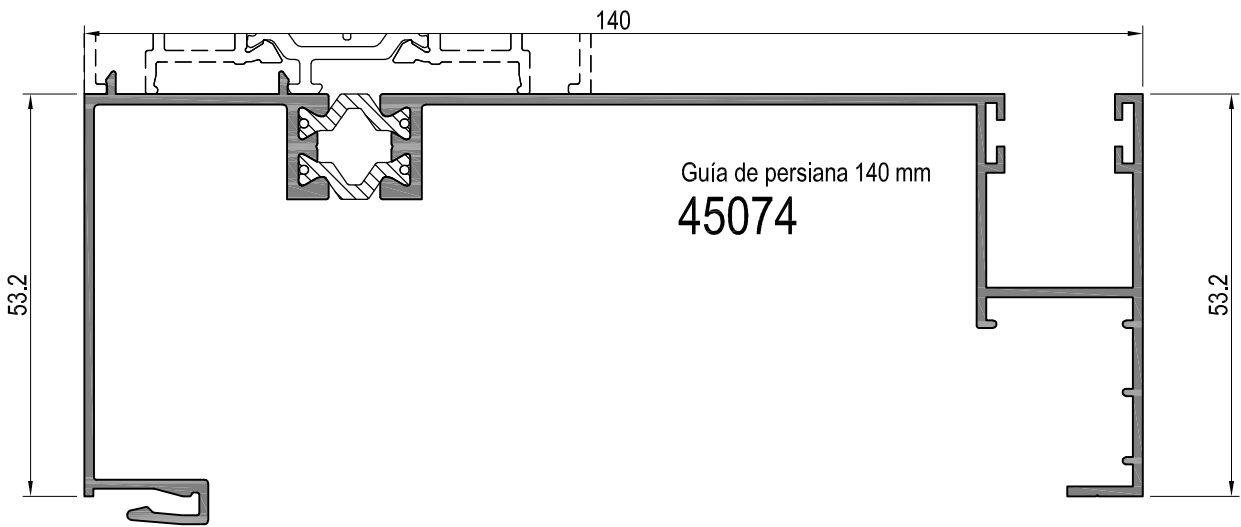

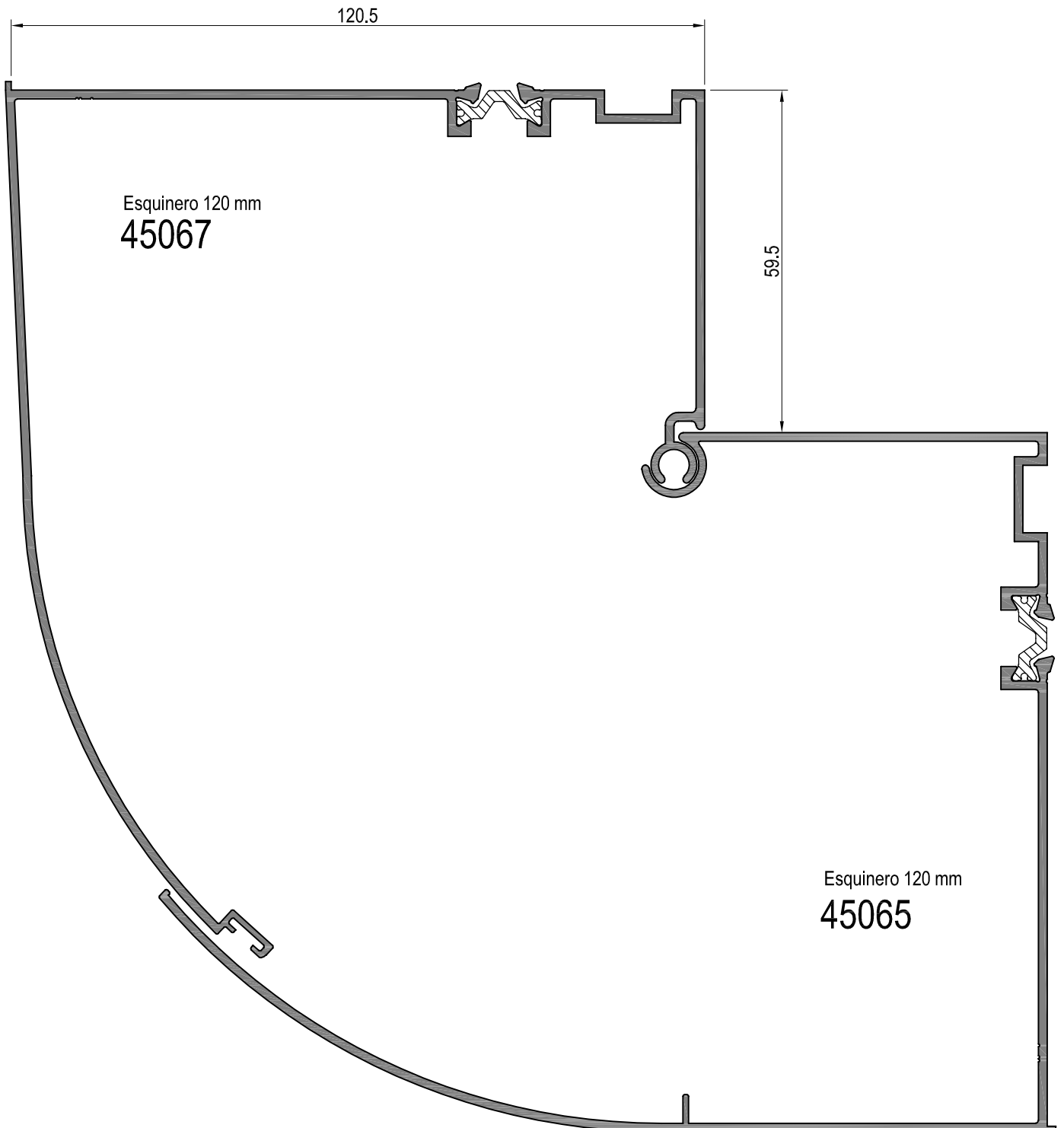

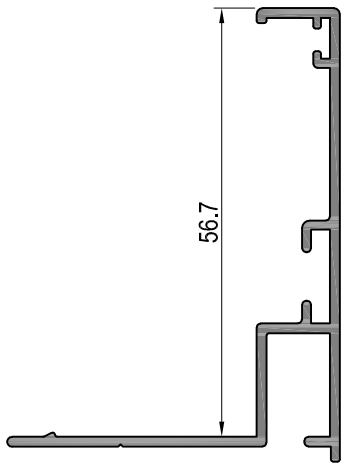

A-10481

EN DESARROLLO

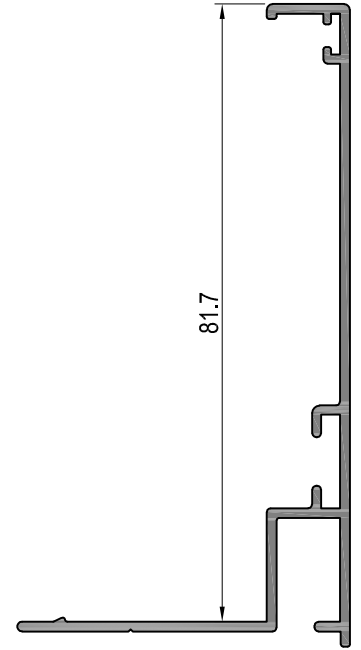
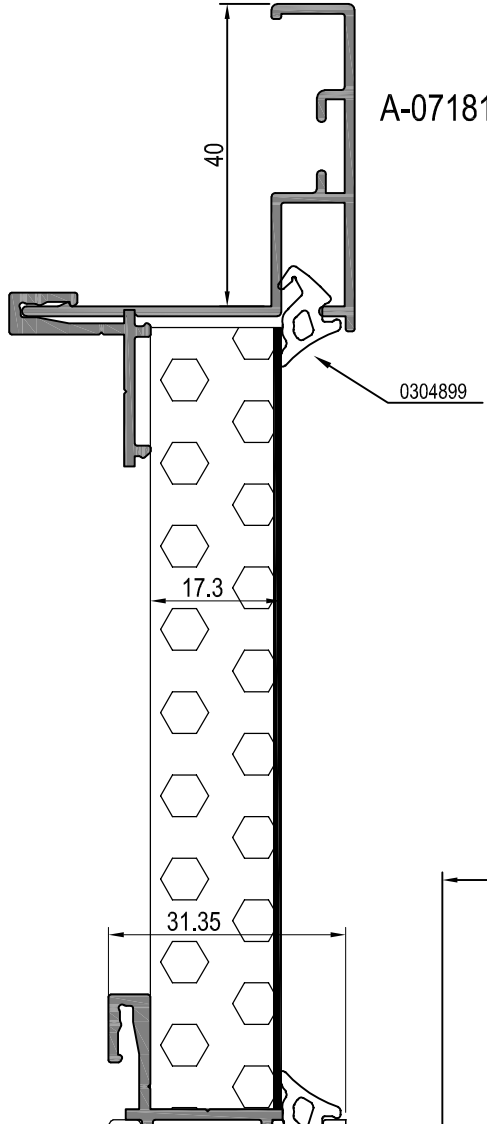
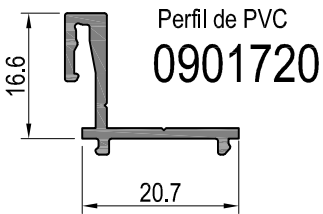

A-10482

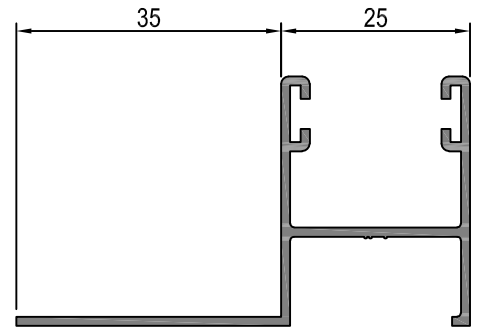

CI-010-20117

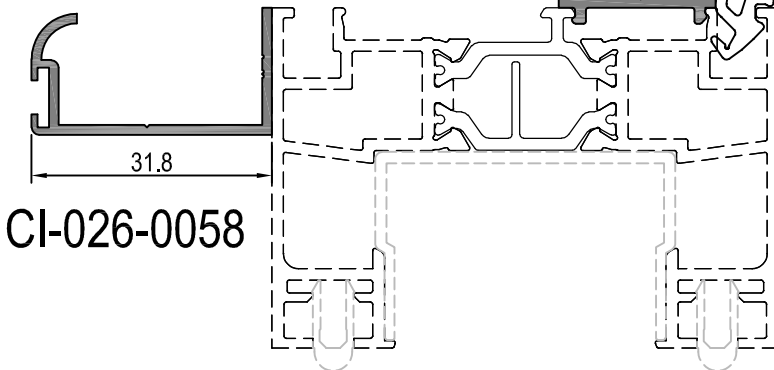

CI-026-0058

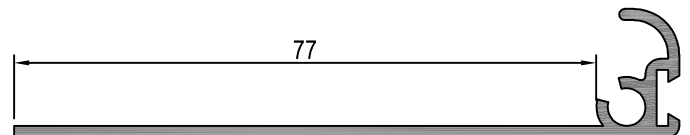

CI-164-1210

SITUACIÓN DE LOS CALZOS DE ACRISTALAMIENTO SEGÚN APERTURA

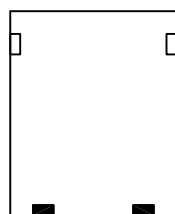

BASTIDOR
FIJO

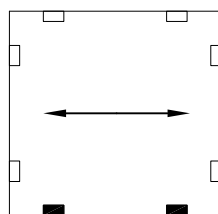

BASTIDOR
DESLIZANTE

Nota:

Los calzos deben colocarse sobre los ejes del carro de deslizamiento.

Nomenclaturas de los calzos

- Calzo de apoyo
- Calzo de colocación

Notas:

- Los calzos deben colocarse según los croquis arriba indicados.
- La distancia entre el eje del calzo y el borde del vidrio será de $L/10$, siendo L la longitud del lado donde se emplazan.

Acristalamiento

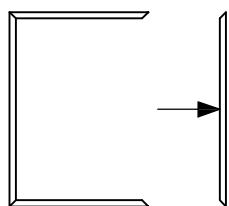

1 - Preparacion del bastidor



2 - Colocar calzos y rellenar con espuma de poliuretano

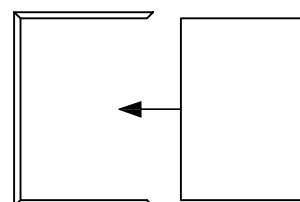

3 - Introducir Vidrio en hoja

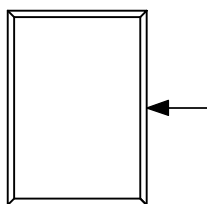

4 - Comprobar y montar hoja

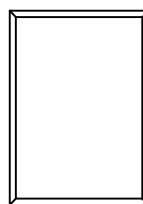

5 - Colocar juntas vidrio

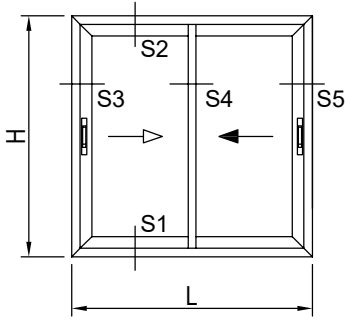

SECCIÓN 2

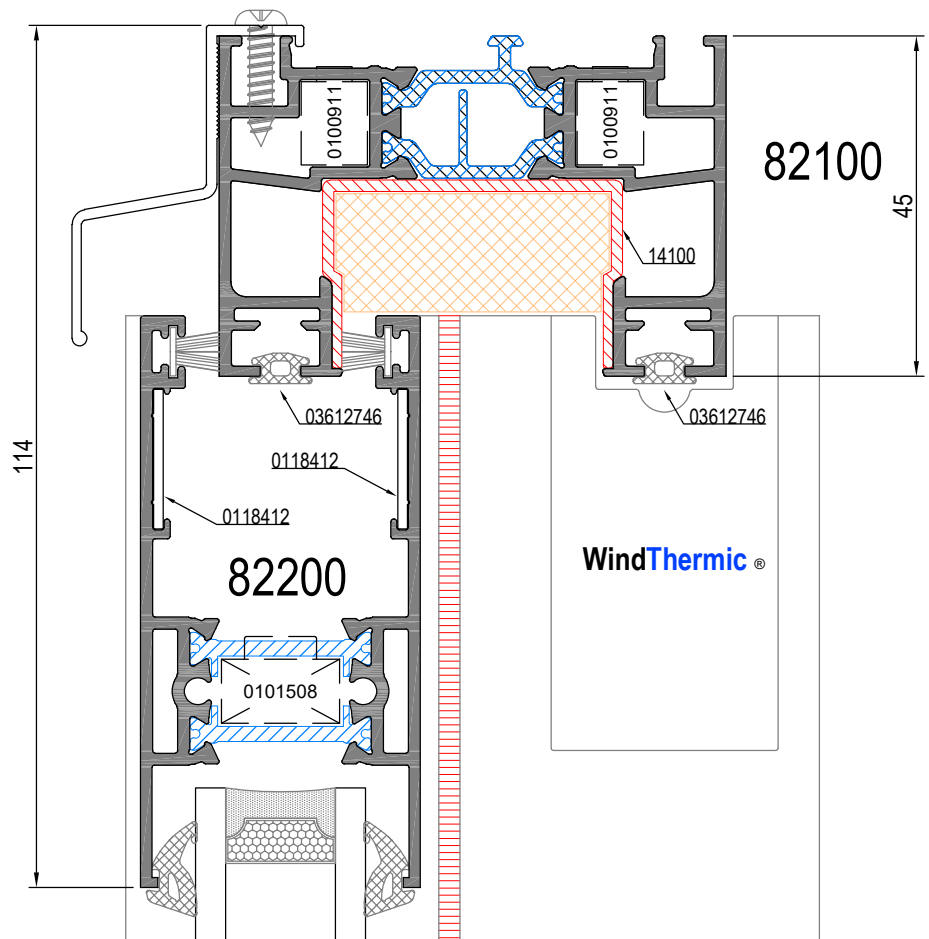

SECCIÓN 1

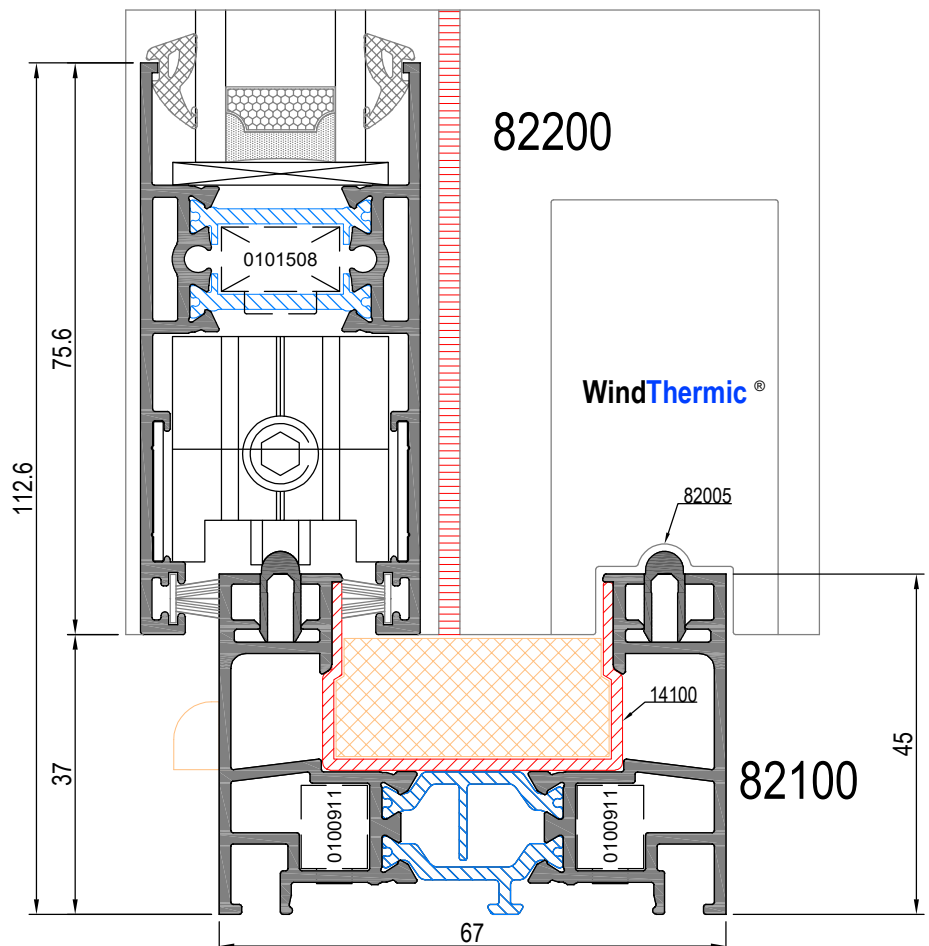

OPCIÓN CON
CORTAVIENTOS

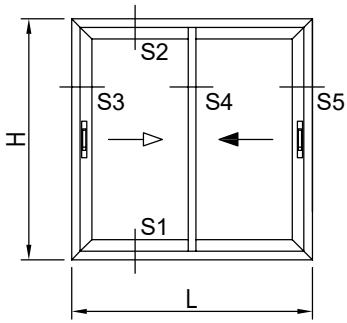

SECCIÓN 1

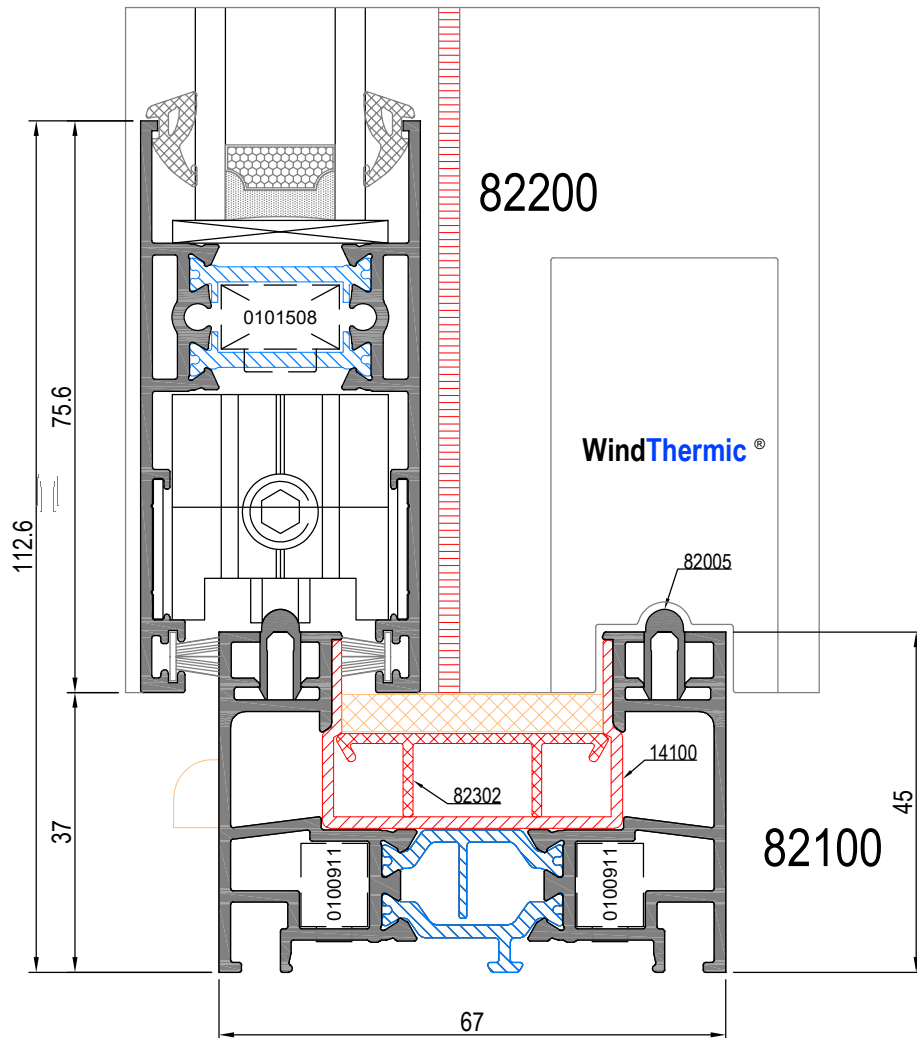

OPCIÓN CON
SUPLEMENTO DE U

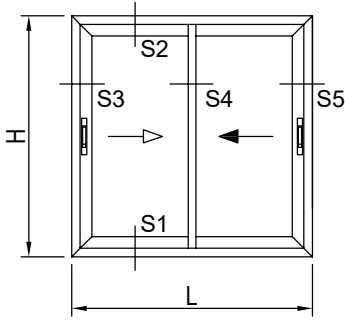

SECCIÓN 1
(marco 83)

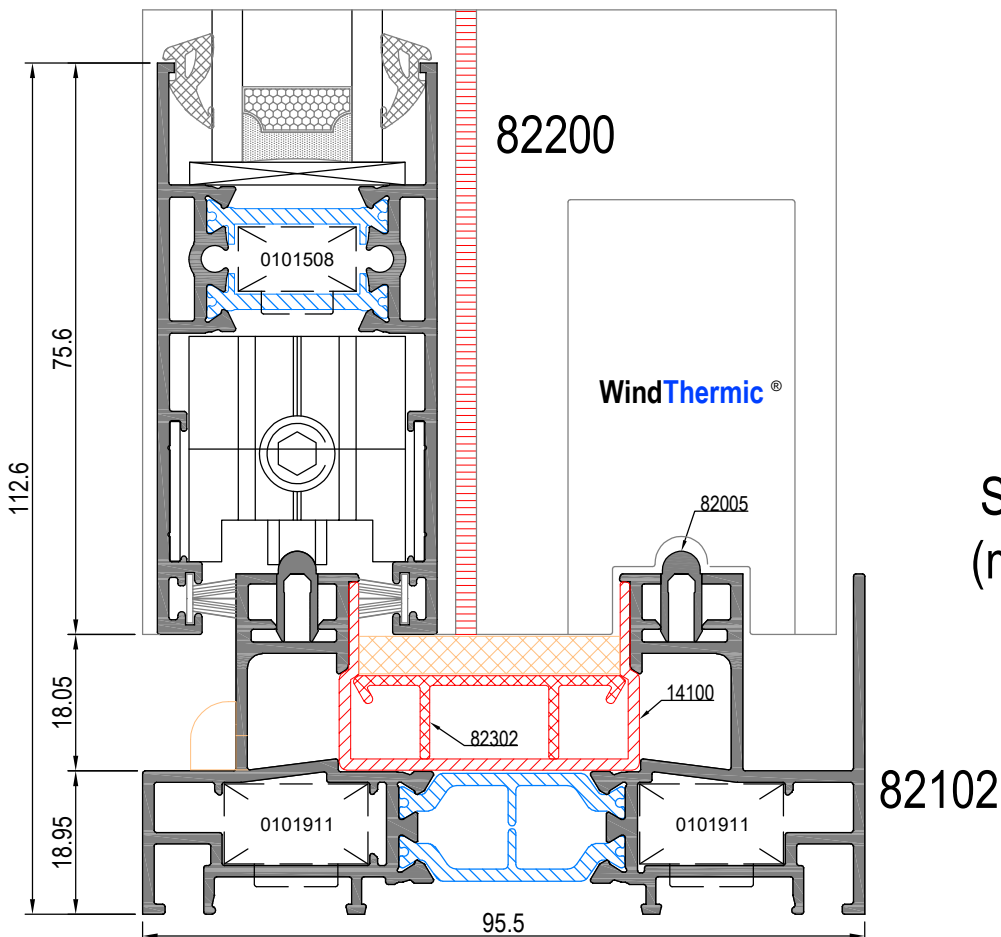
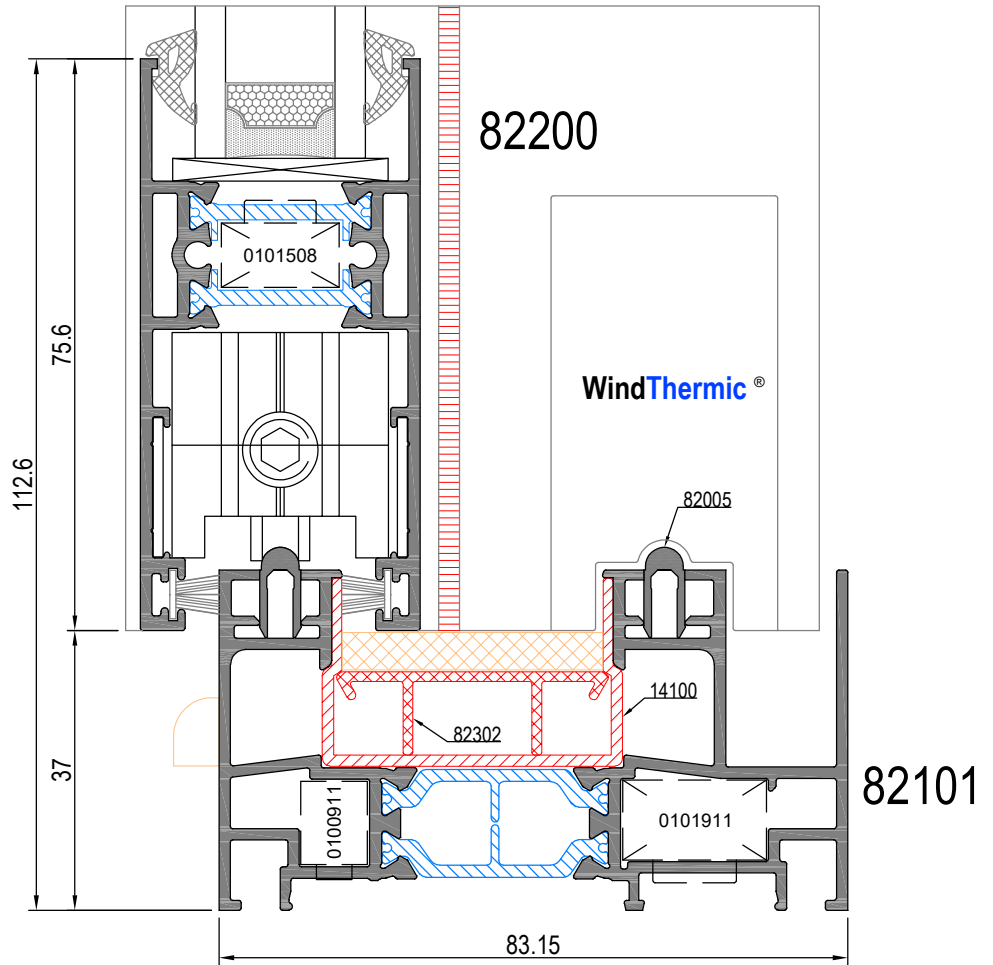

SECCIÓN 1
(marco 95.5)

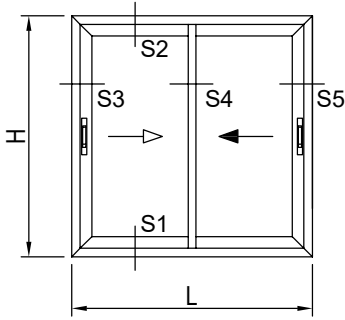

SECCIÓN 3

SECCIÓN 4

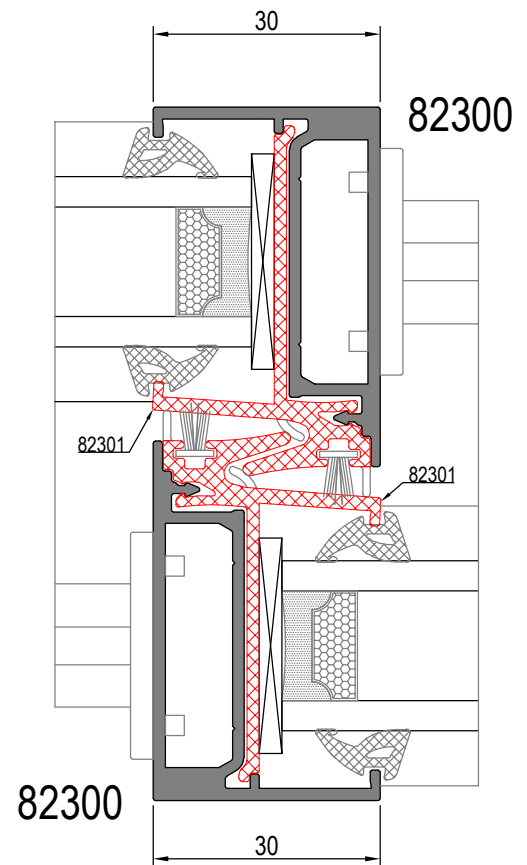
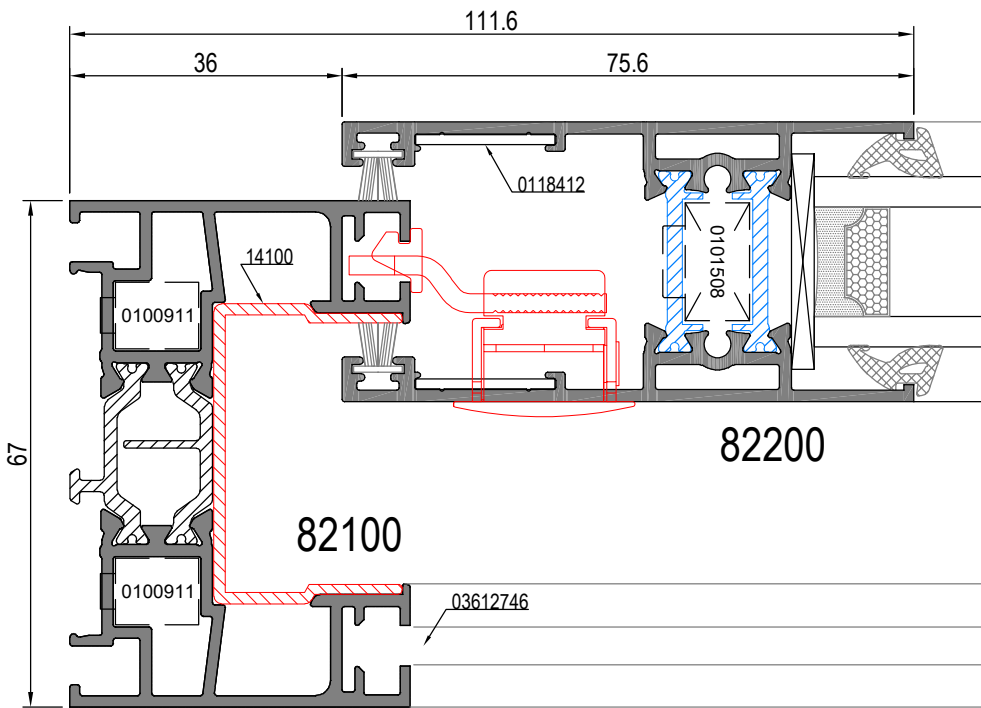

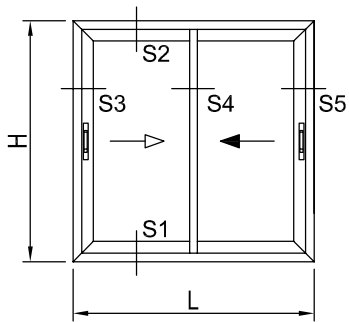

SECCIÓN 5

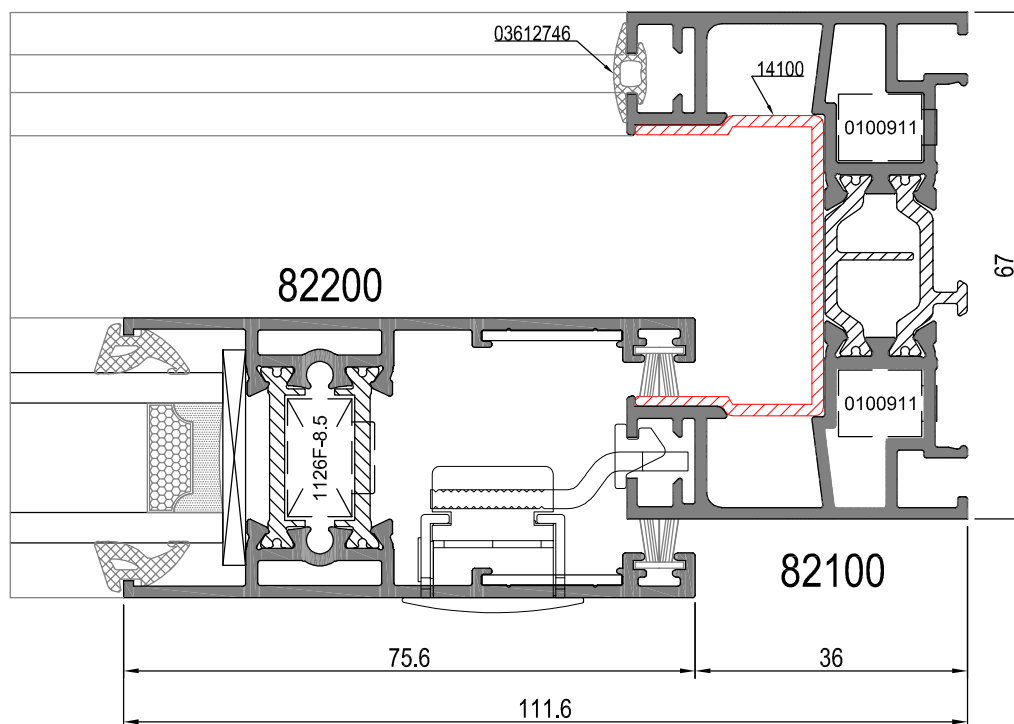

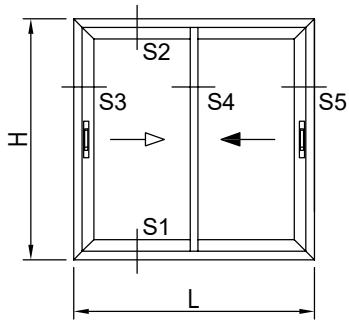

SECCIÓN 5

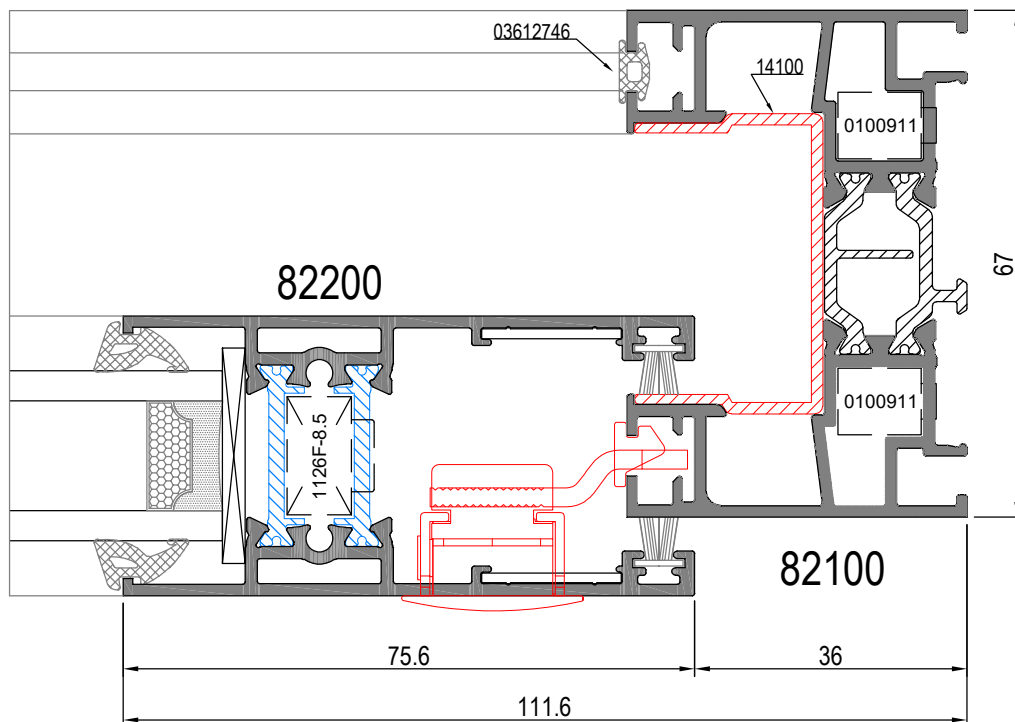

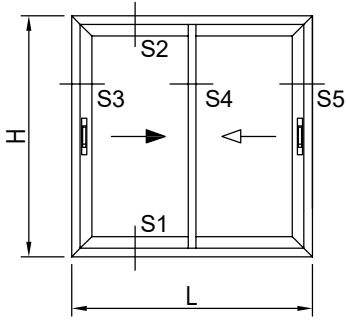

SECCIÓN 3

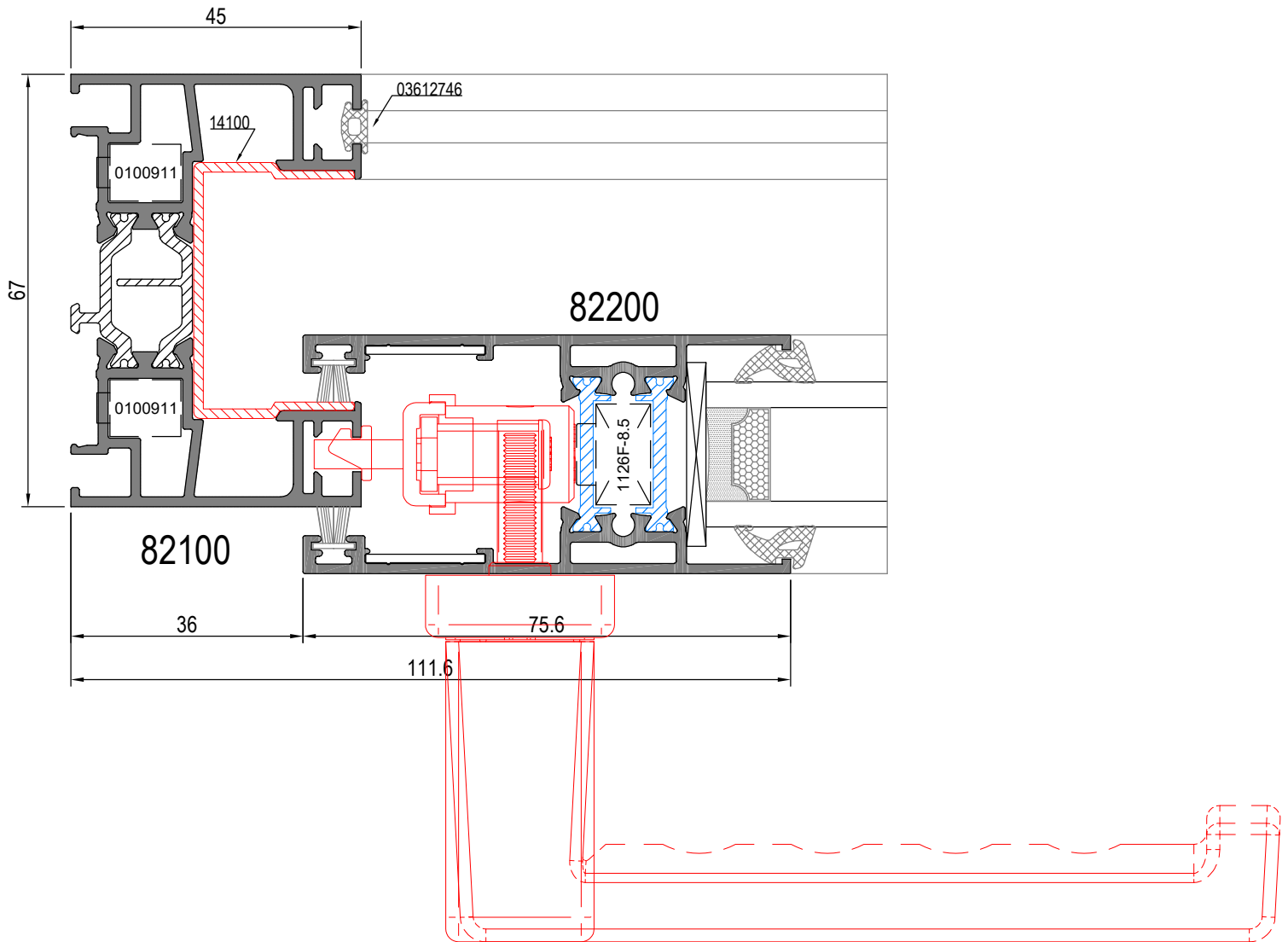

Opción multipunto

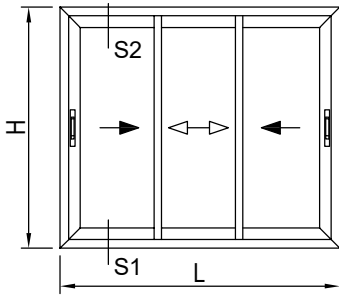

SECCIÓN 2

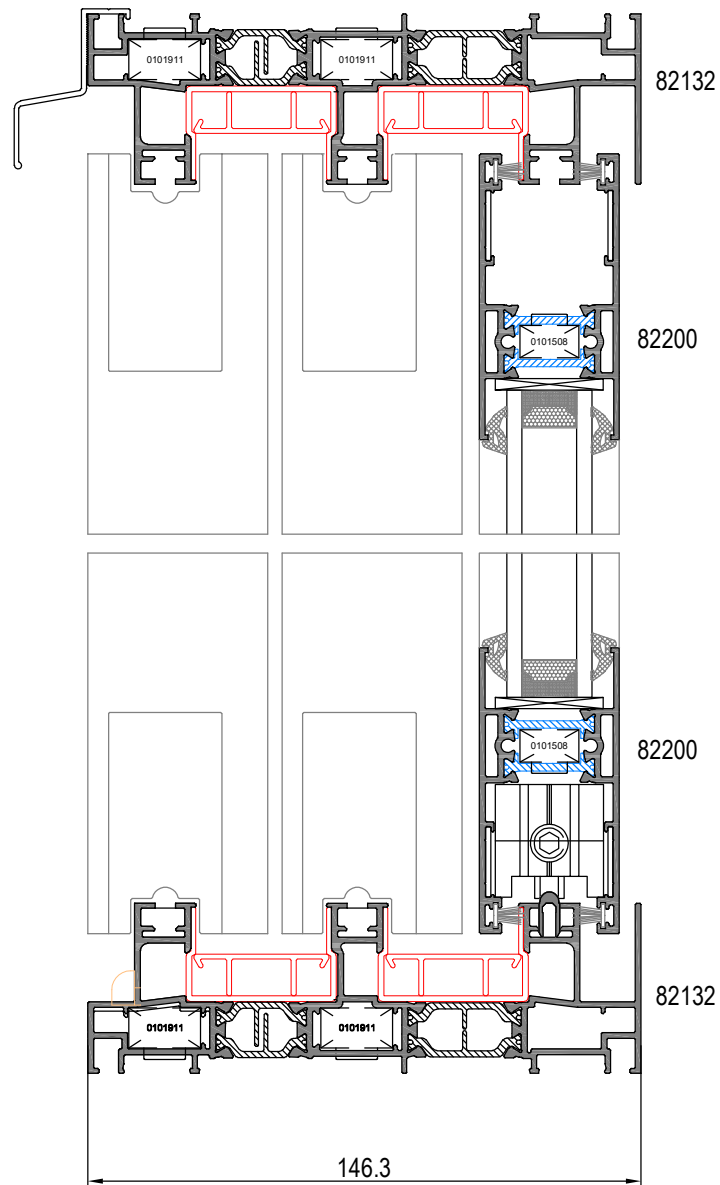

Escala 1:2

SECCIÓN 1

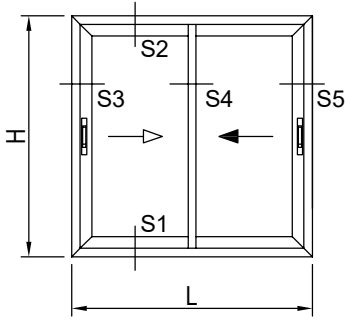

SECCIÓN 4

PERFILES DE CRUCE CON REFUERZO

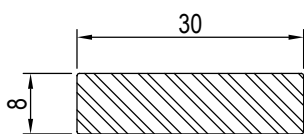
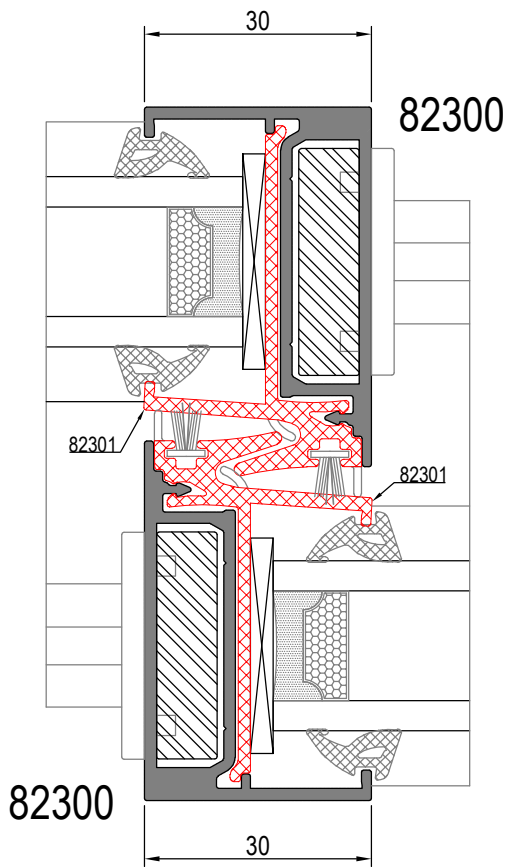

Refuerzo 30x8

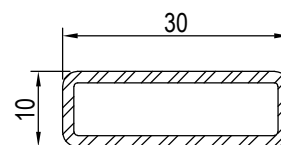
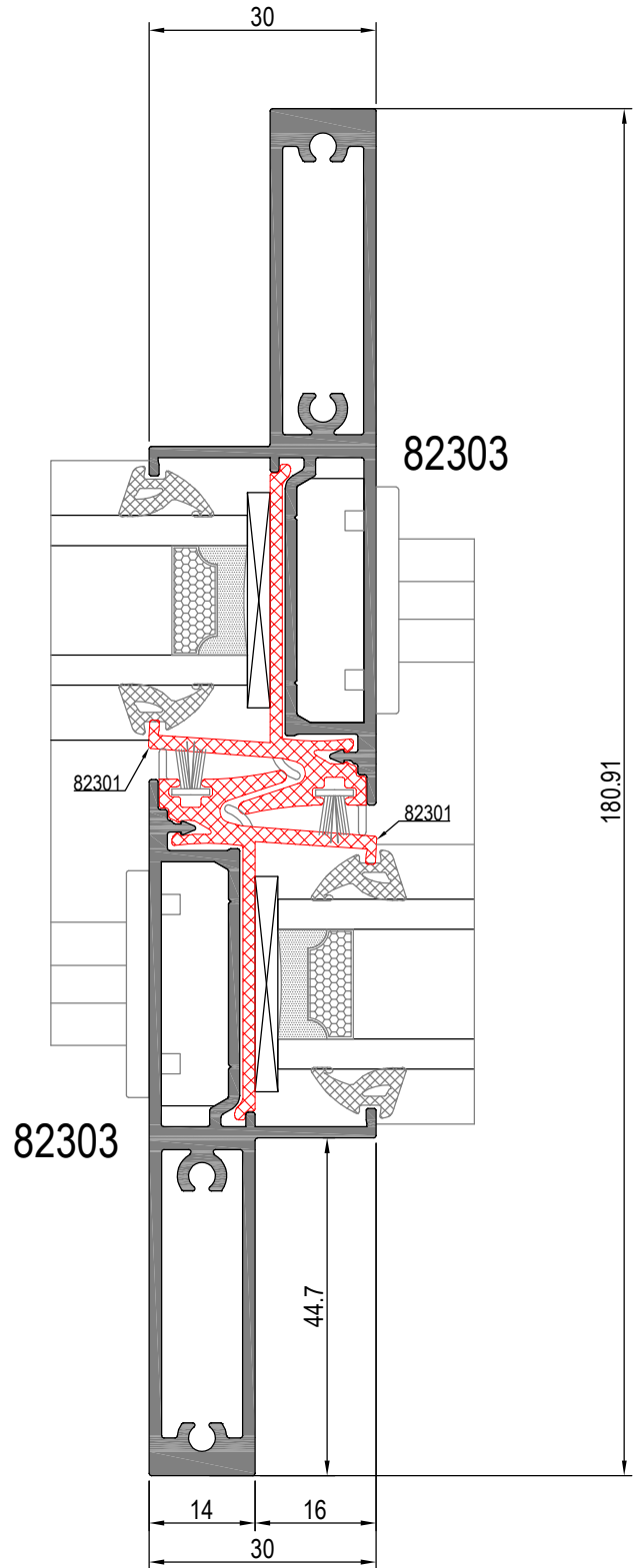

Refuerzo 30x10

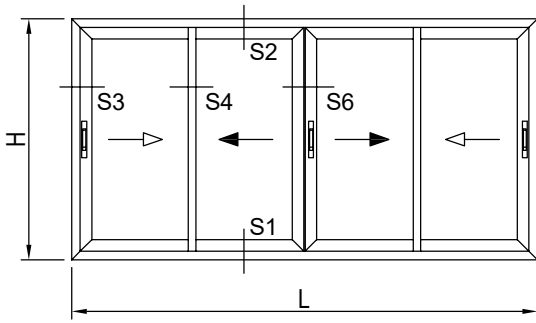

SECCIÓN 6

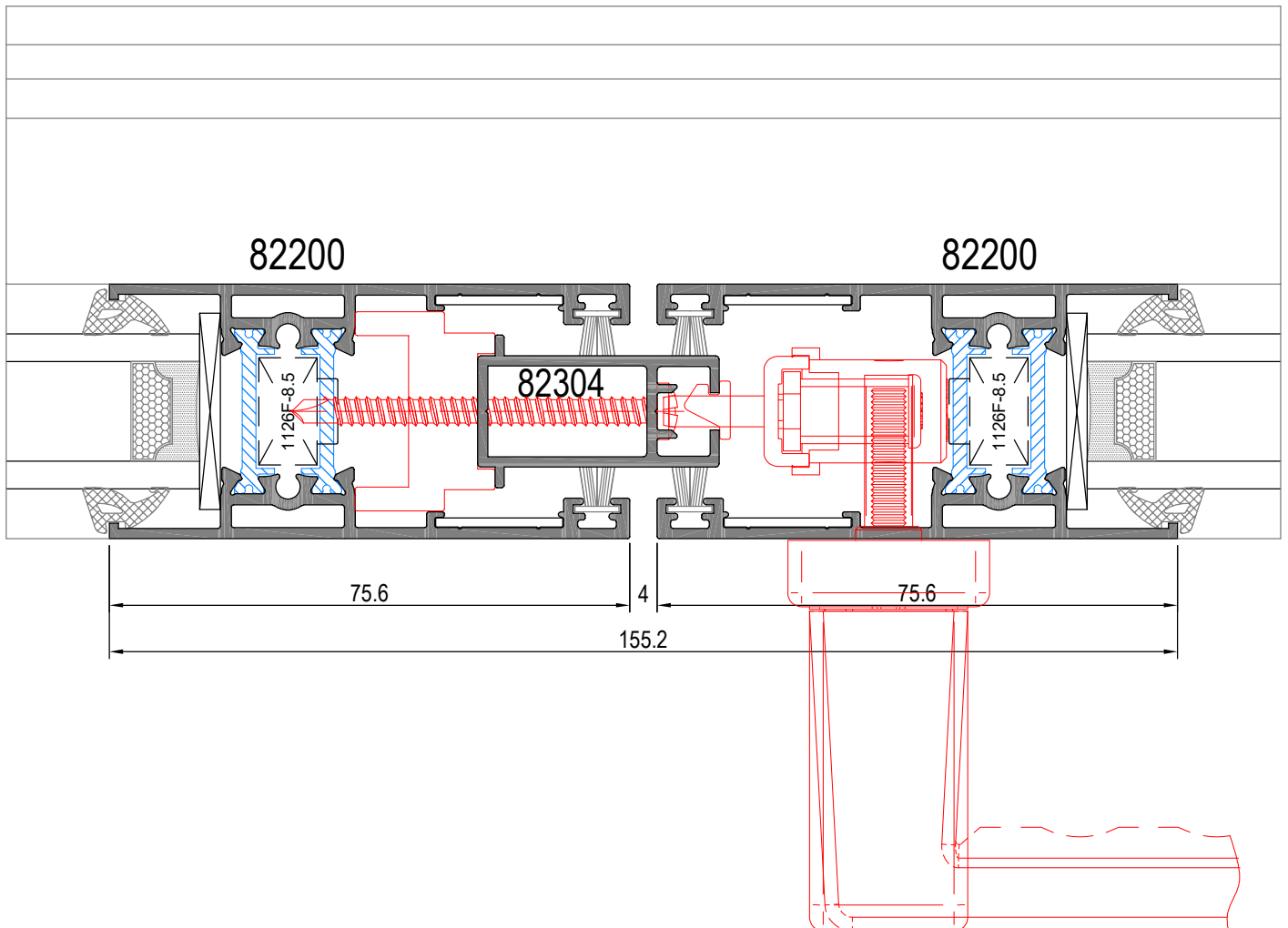

Ventana corredera 2 hojas

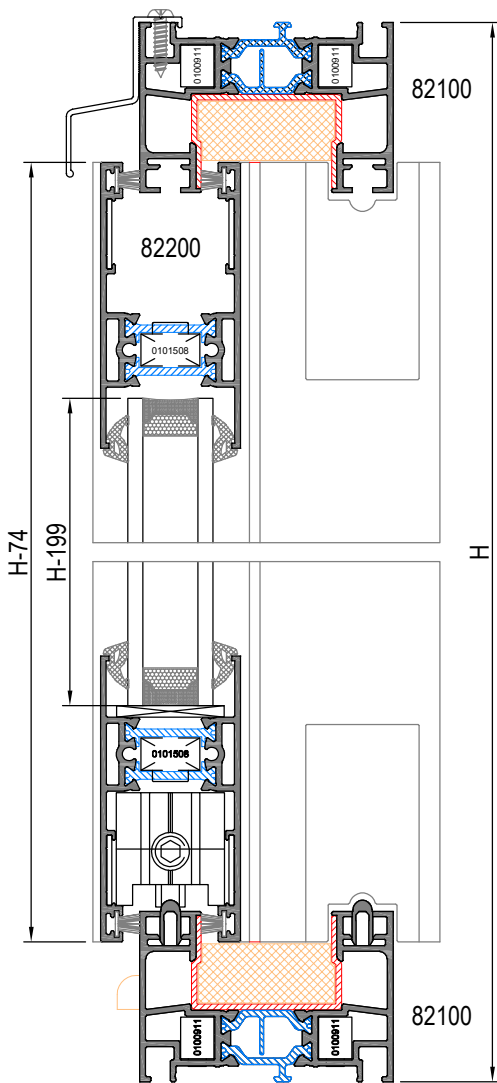

Den.	Und.	Referenc.	Descripción	Corte	Medidas
Marco	2	82100	Marco lateral		H
	2	82100	Marco superior / inferior		L
Hoja	2	82200	Hoja lateral		H - 74
	4	82200	Hoja superior / inferior		L/2 - 35
	2	82300	Hoja central		H - 74
	2	82005	Carril rodadura inferior		L - 74
	4	14100	U marco		2H + 2L
	2	82301	Suplemento cruce		H - 74
Acristalamiento			L/2-100 x H-199		

Den.	Unidades	Referenc.	Descripción
Accesorios	8	0100911	Escuadra 9 x 11
	4	0101508	Escuadra 15 x 8
	8	0118412	Escuadra alineamiento 18 x 1
	2	177019	Conjunto tapas cruce 1 hoja
	2	177020	Conjunto tope lateral 1 hoja
	1	177021	Cortavientos superior/inferior
	4		Ruedas (según peso)
	2	0509025	Tapa salida de agua
Juntas	4L + 4H	0106575	Felpa TRI-FIN 6,5x7,5 negro
	2H	0105070	Felpa TRI-FIN 5x7 negro
	2L + 4H	03612746	Junta cierre canal marco
	4L + 4H		Junta acristalar (según vidrio)
Herraje	2 uds.	0814506	Cierre embutido (gancho inc.)
	2 uds.	0810010	Cerradero marco

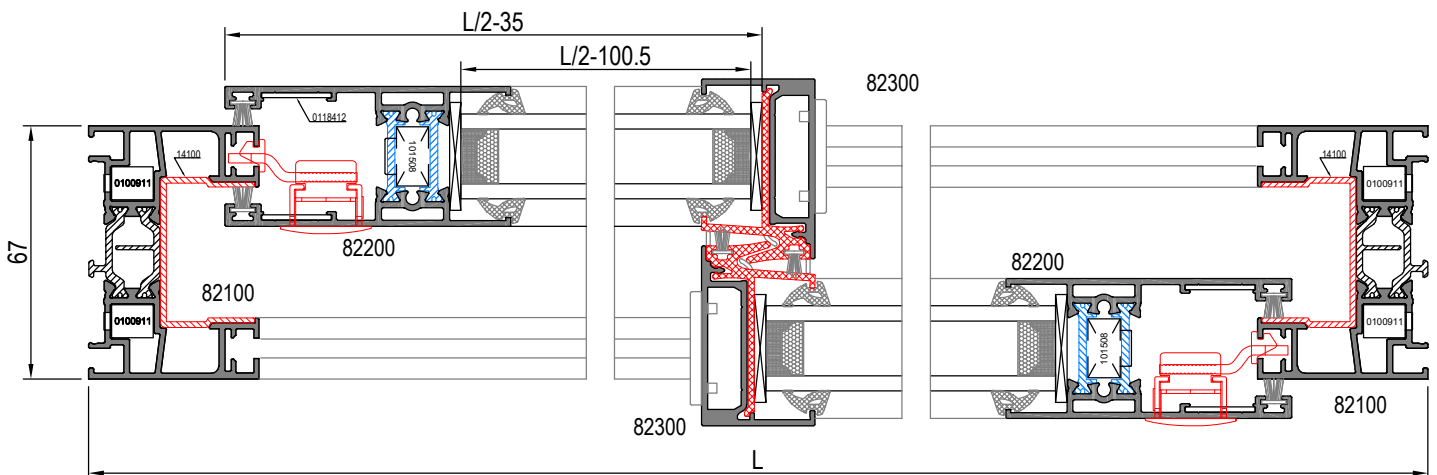
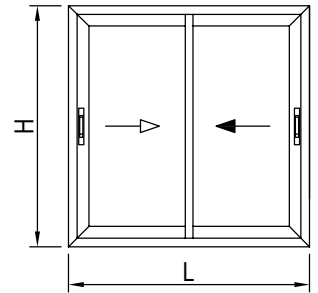

Escala 1:2

Ventana corrdera 3 hojas 2 carriles

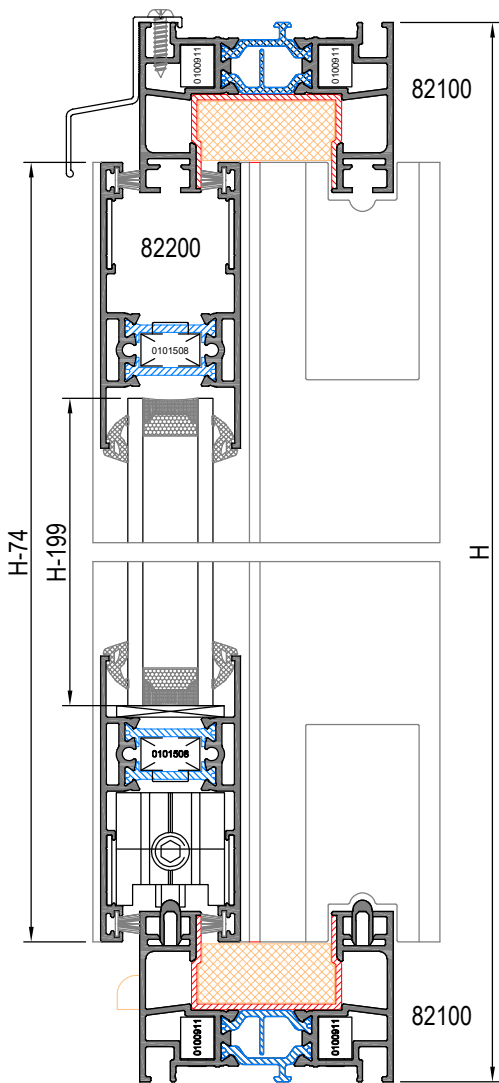

Den.	Und.	Referenc.	Descripción	Corte	Medidas
Marco	2	82100	Marco lateral		H
	2	82100	Marco superior / inferior		L
Hoja	2	82200	Hoja lateral		H - 74
	4	82200	Hoja sup / inf hoja lateral		L/3 - 2.8
	2	82200	Hoja sup / inf hoja central		L/3 - 62.4
	4	82300	Hoja central		H - 74
	2	82005	Carril rodadura inferior		L - 74
	4	14100	U marco		2H + 2L
	4	82301	Suplemento cruce		H - 74
Acristalamiento			L/3-68 x H-199		

Den.	Unidades	Referenc.	Descripción
Accesorios	8	0100911	Escuadra 9 x 11
	4	0101508	Escuadra 15 x 8
	8	0118412	Escuadra alineamiento 18 x 1
	4	177019	Conjunto tapas cruce 1 hoja
	2	177020	Conjunto tope lateral 1 hoja
	2	177021	Cortavientos superior/inferior
	6		Ruedas (según peso)
	2	0509025	Tapa salida de agua
Juntas	4L + 4H	0106575	Felpa TRI-FIN 6,5x7,5 negro
	4H	0105070	Felpa TRI-FIN 5x7 negro
	2L + 4H	03612746	Junta cierre canal marco
	4L + 4H		Junta acristalar (según vidrio)
Herraje	2 uds.	0814506	Cierre embutido (gancho inc.)
	2 uds.	0810010	Cerradero marco

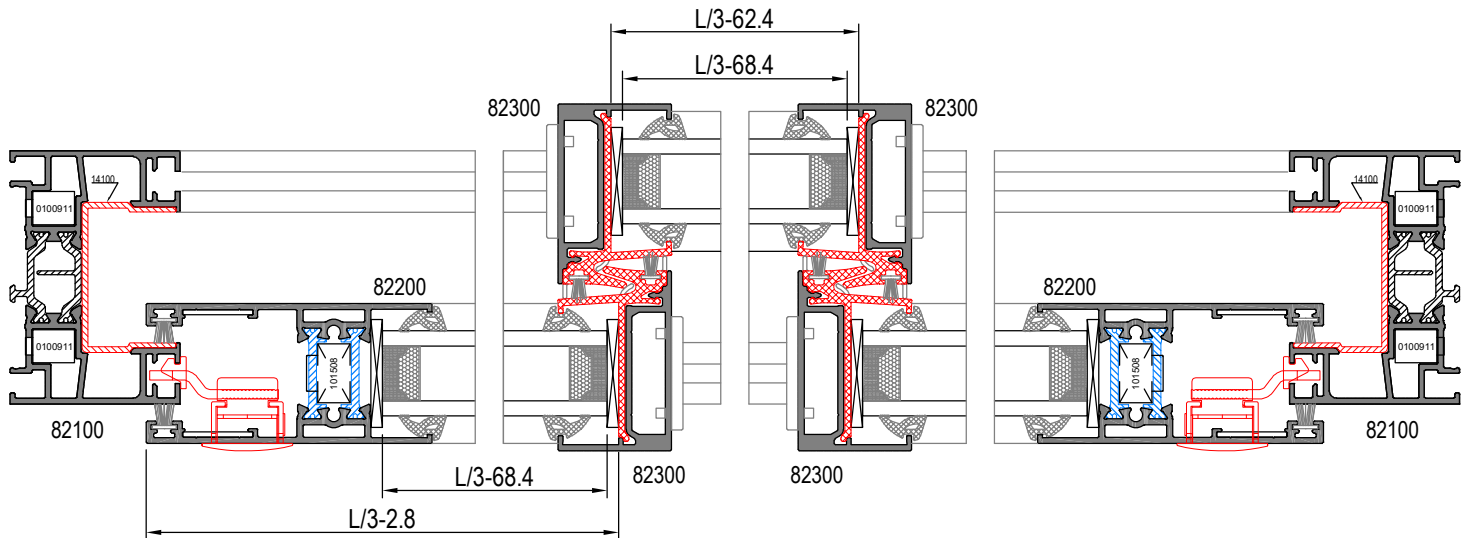
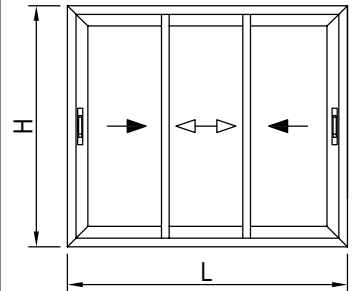

Escala 1:2

Ventana corredera 3 hojas 3 carriles

Escala 1:2

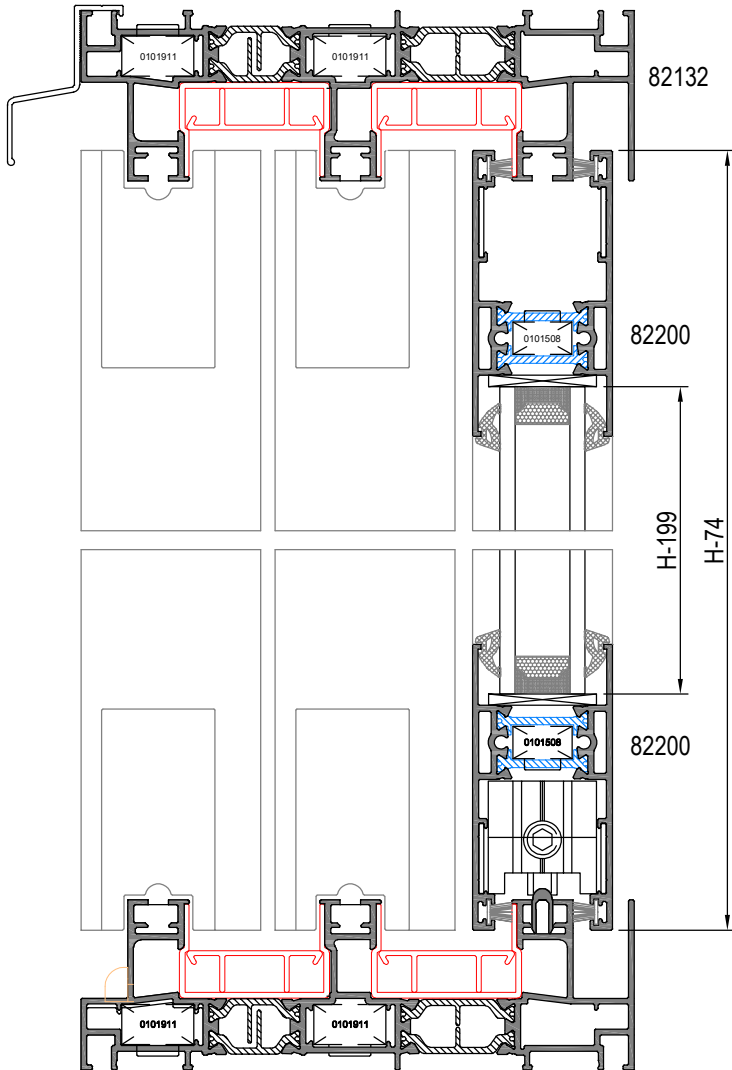
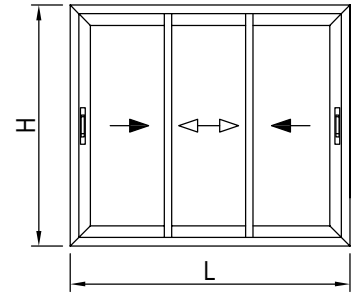

Den.	Und.	Referenc.	Descripción	Corte	Medidas
Marco	2	82132	Marco lateral		H
	2	82132	Marco superior / inferior		L
Hoja	2	82200	Hoja lateral		H - 74
	4	82200	Hoja sup / inf hoja lateral		L/3 - 2.8
	2	82200	Hoja sup / inf hoja central		L/3 - 62.4
	4	82300	Hoja central		H - 74
	3	82005	Carril rodadura inferior		L - 74
8	14100	U marco			2H + 2L
4	82301	Suplemento cruce			H - 74
8	82302	Perfil PVC para marco			2H + 2L
Acristalamiento			L/3-68 x H-199		

Den.	Undidades	Referenc.	Descripción
Accesorios	12	0101911	Escuadra 19.5 x 11
	4	0101508	Escuadra 15 x 8
	8	0118412	Escuadra alineamiento 18 x 1
	4	177019	Conjunto tapas cruce 1 hoja
	2	177020	Conjunto tope lateral 1 hoja
	2	177021	Cortavientos superior/inferior
	6		Ruedas (según peso)
	2	0509025	Tapa salida de agua
Juntas	4L + 4H	0106575	Felpa TRI-FIN 6,5x7,5 negro
	4H	0105070	Felpa TRI-FIN 5x7 negro
	2L + 4H	03612746	Junta cierre canal marco
	4L + 4H		Junta acristalar (según vidrio)
Herraje	2 uds.	0814506	Cierre embutido (gancho inc.)
	2 uds.	0810010	Cerradero marco

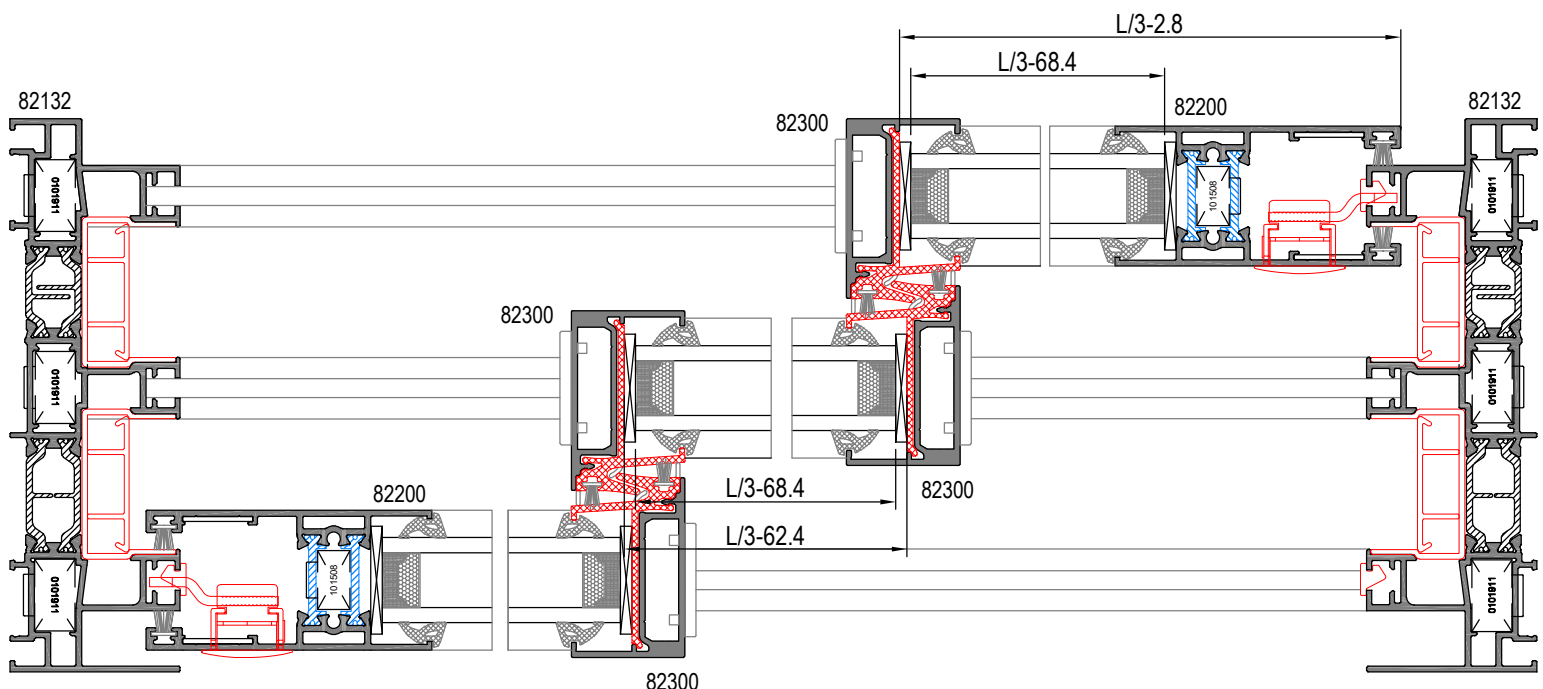

Ventana corredera 4 hojas 2 carriles

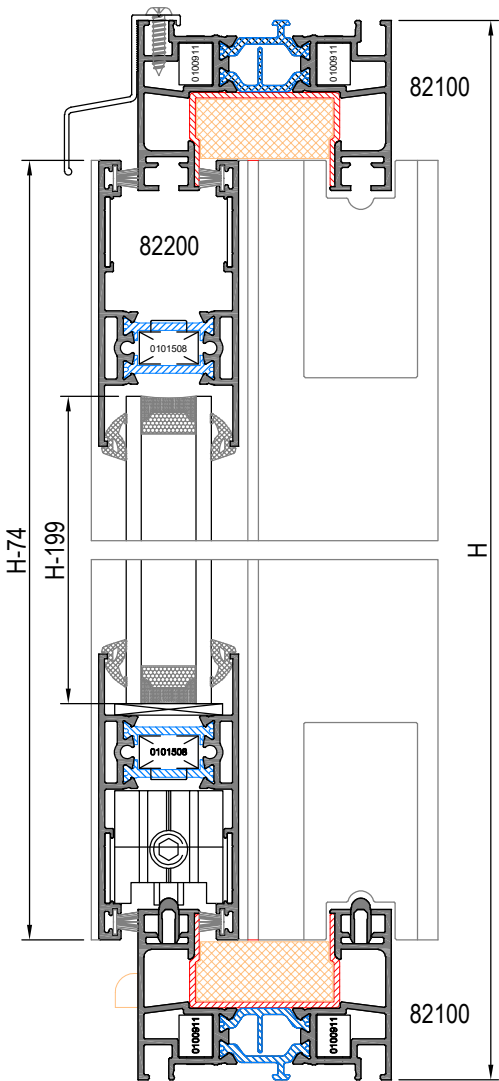
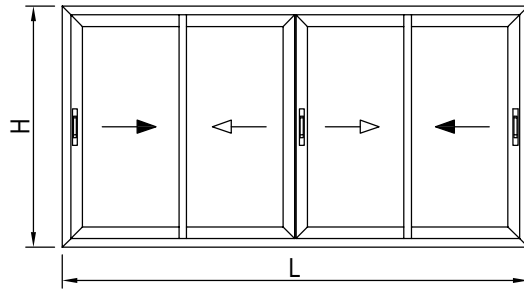

Den.	Und.	Referenc.	Descripción	Corte	Medidas
Marco	2	82100	Marco lateral		H
	2	82100	Marco superior / inferior		L
Hoja	4	82200	Hoja lateral		H - 74
	8	82200	Hoja superior / inferior		L/4 - 18
	4	82300	Hoja central		H - 74
	2	82005	Carril rodadura inferior		L - 74
	1	82304	Perfil 4 hojas		H - 120
	4	14100	U marco		2H + 2L
	4	82301	Suplemento cruce		H - 74
Acristalamiento			4 uds L/4-83.5 x H-199		

Den.	Undidades	Referenc.	Descripción
Accesorios	8	0100911	Escuadra 9 x 11
	8	0101508	Escuadra 15 x 8
	16	0118412	Escuadra alineamiento 18 x 1
	4	177019	Conjunto tapas cruce 1 hoja
	3	177020	Conjunto tope lateral 1 hoja
	3	177021	Cortavientos superior/inferior
	8		Ruedas (según peso)
	2 - 4	0509025	Tapa salida de agua
	2	0000070	Tapa 4 hojas
	-	0000080	Centrador (Cada 250 mm)
Juntas	4L + 6H	0106575	Felpa TRI-FIN 6,5x7,5 negro
	4H	0105070	Felpa TRI-FIN 5x7 negro
	2L + 4H	03612746	Junta cierre canal marco
	4L + 4H		Junta acristalar (según vidrio)
Herraje	3 uds.	0814506	Cierre embutido (gancho inc.)
	3 uds.	0810010	Cerradero marco

Escala 1:2

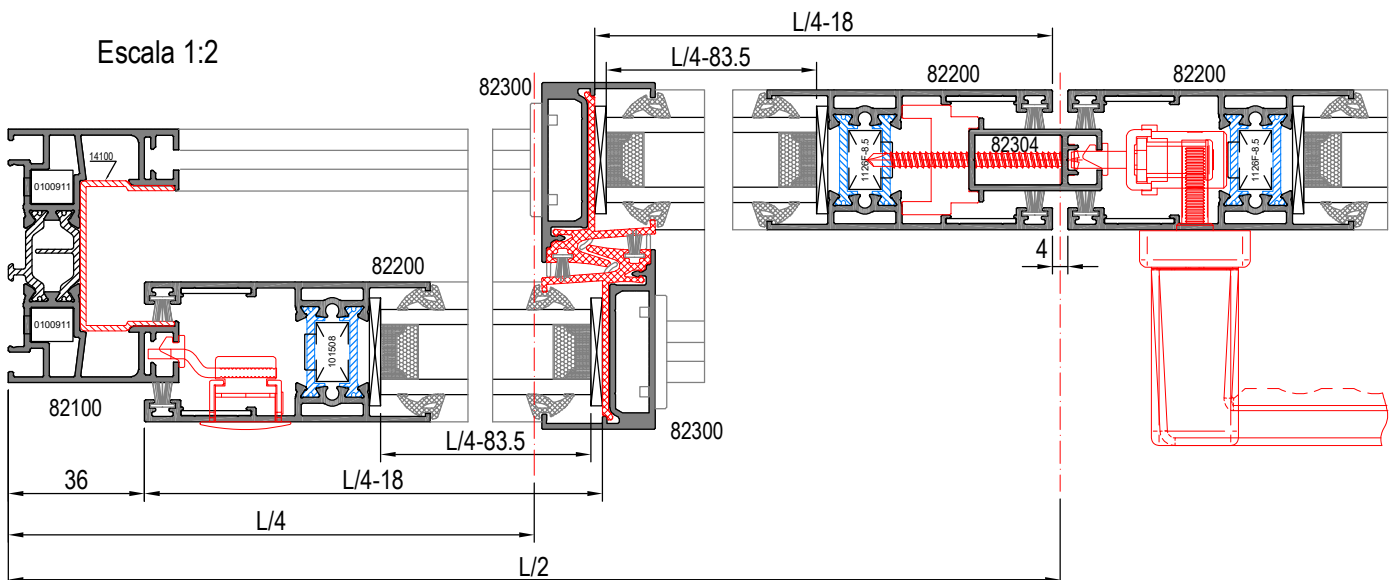

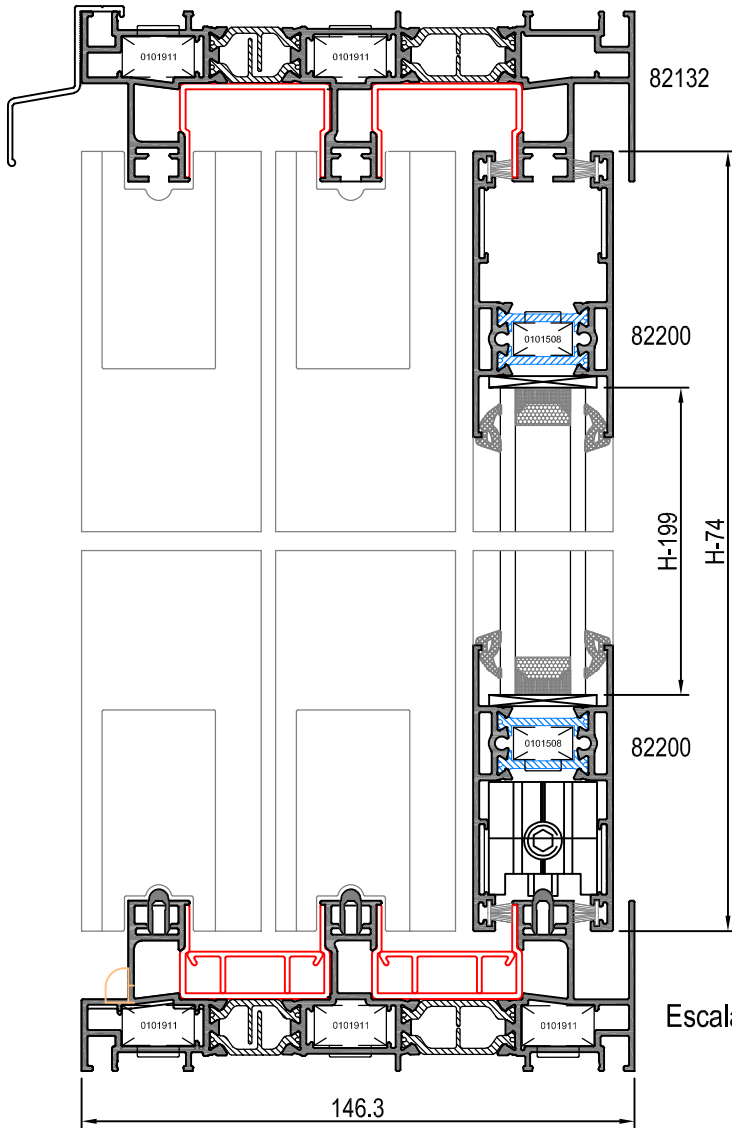

Escala 1:2

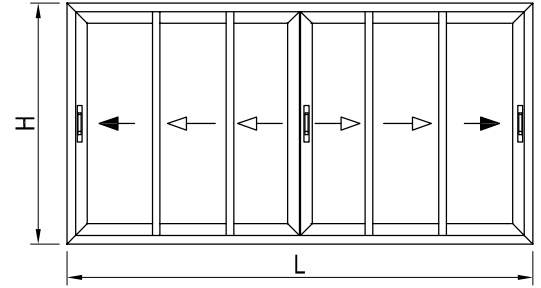

Den.	Und.	Referenc.	Descripción	Corte	Medidas
Marco	2	82132	Marco lateral		H
	2	82132	Marco superior / inferior		L
Hoja	4	82200	Hoja lateral		H - 74
	12	82200	Hoja superior / inferior		L/6 + 8,5
	8	82300	Hoja central		H - 74
	3	82005	Carril rodadura inferior		L - 74
	1	82304	Perfil 4 hojas		H - 120
	4	14100	U marco		2H + 2L
	6	82301	Suplemento cruce		H - 74
	2	82302	Perfil PVC marco		L - 41
Acristalamiento			6 uds L/6-57 x H-199		

Den.	Undidades	Referenc.	Descripción	
Accesorios	12	0100911	Escuadra 9 x 11	
	8	0101508	Escuadra 15 x 8	
	16	0118412	Escuadra alineamiento 18 x 1	
	8	177019	Conjunto tapas cruce 1 hoja	
	3	177020	Conjunto tope lateral 1 hoja	
	4	177021	Cortavientos superior/inferior	
	12		Ruedas (según peso)	
	2 - 4	0509025	Tapa salida de agua	
	2	0000070	Tapa 4 hojas	
	-	0000080	Centrador (Cada 250 mm)	
	Juntas	4L + 8H	0106575	Felpa TRI-FIN 6,5x7,5 negro
		8H	0105070	Felpa TRI-FIN 5x7 negro
3L + 6H		03612746	Junta cierre canal marco	
4L + 8H			Junta acristalar (según vidrio)	
Herraje	3 uds.	0814506	Cierre embutido (gancho inc.)	
	3 uds.	0810010	Cerradero marco	

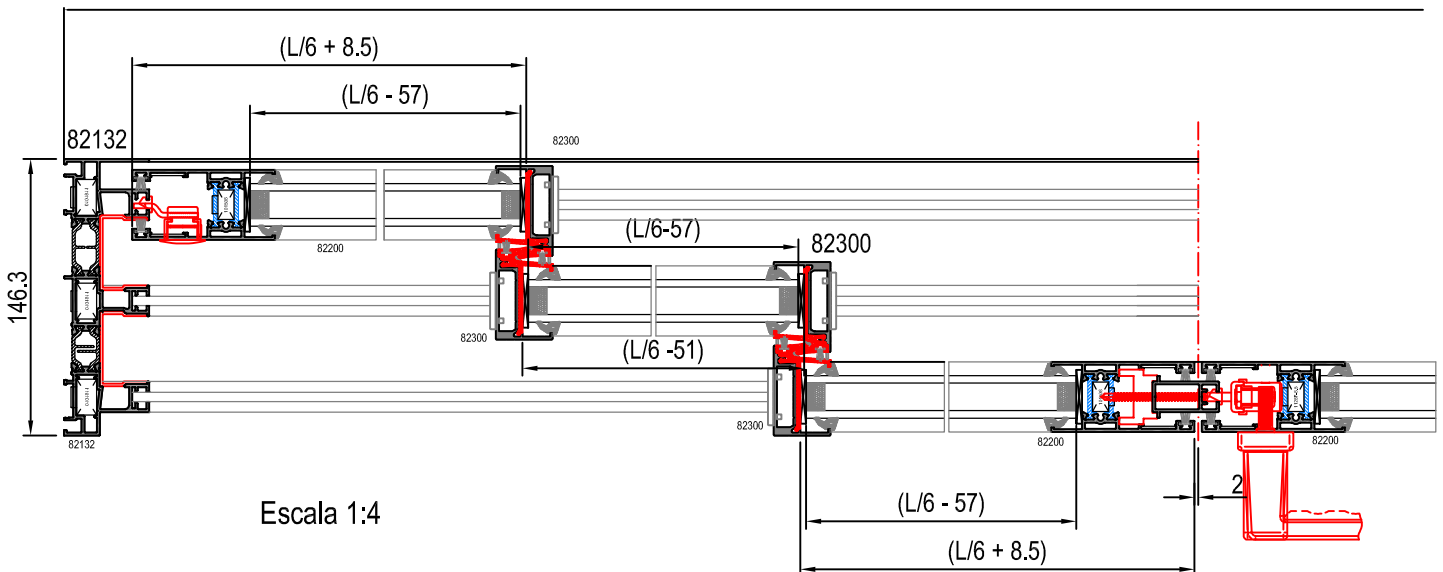

Escala 1:4

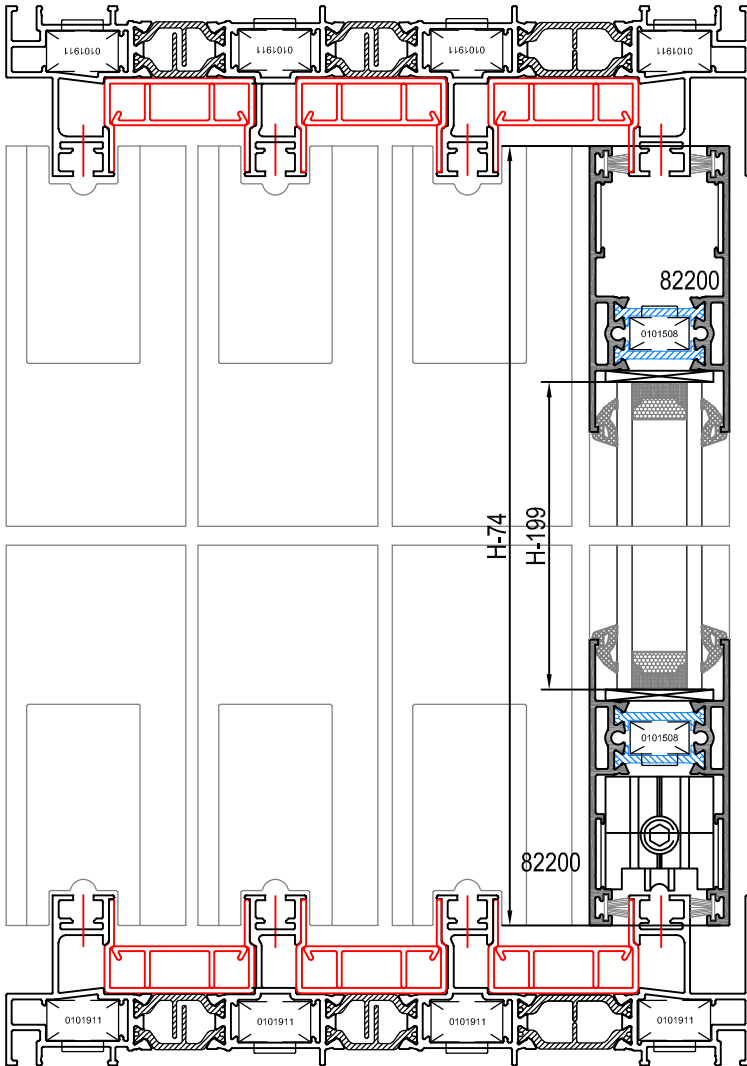
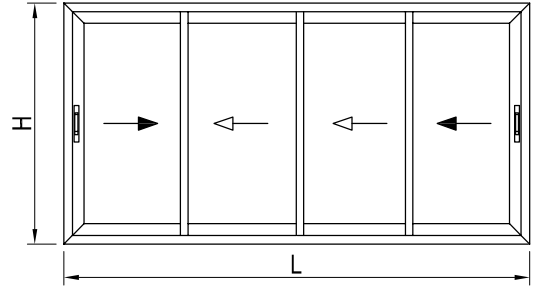

Den.	Und.	Referenc.	Descripción	Corte	Medidas
Marco	2	82132	Marco lateral		H
	2	82132	Marco superior / inferior		L
Hoja	2	82200	Hoja lateral		H - 74
	4	82200	Hoja superior / inferior		L/4 - 13.25
	4	82200	Hoja superior / inferior		L/4 - 46.25
	6	82300	Hoja central		H - 74
	4	82005	Carril rodadura inferior		L - 74
	6	14100	U marco		H
6	14100	U marco		L	
6	82301	Suplemento cruce		H - 74	
2	82302	Perfil PVC marco		L - 41	
Acristalamiento			4 uds L/4-52.2 x H-199		

Den.	Undidades	Referenc.	Descripción
Accesorios	16	0100911	Escuadra 9 x 11
	4	0101508	Escuadra 15 x 8
	8	0118412	Escuadra alineamiento 18 x 1
	6	177019	Conjunto tapas cruce 1 hoja
	6	177020	Conjunto tope lateral 1 hoja
	3	177021	Cortavientos superior/inferior
	8		Ruedas (según peso)
	2 - 4	0509025	Tapa salida de agua
	-	0000080	Centrador (Cada 250 mm)
	Juntas	16L + 4H	0106575
6H		0105070	Felpa TRI-FIN 5x7 negro
4L + 8H		03612746	Junta cierre canal marco
16L + 16H			Junta acristalar (según vidrio)
Herraje	2 uds.	0814506	Cierre embutido (gancho inc.)
	2 uds.	0810010	Cerradero marco

Escala 1:2

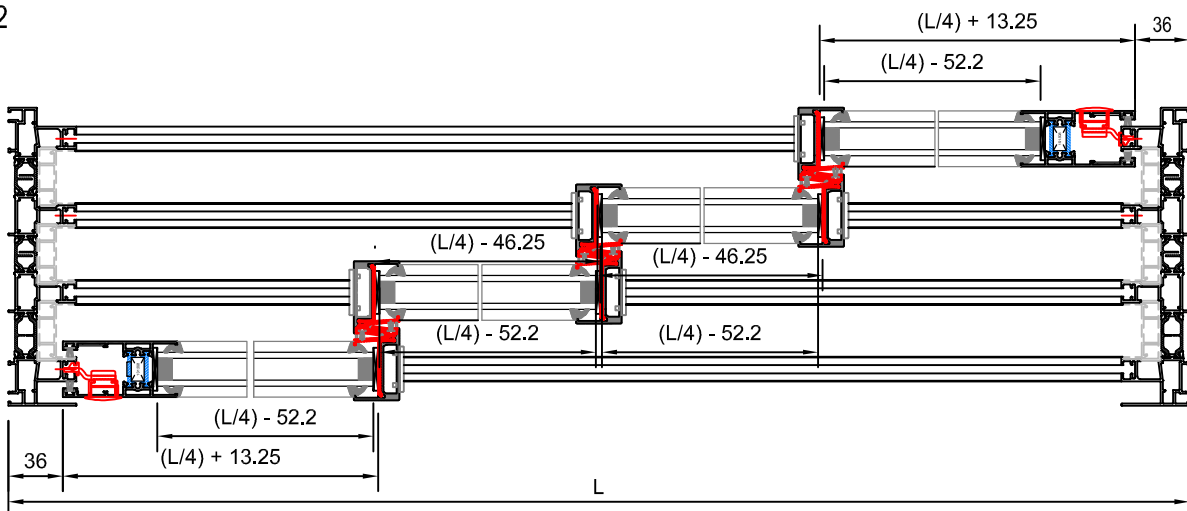

Escala 1:5

